

INSTALLATION MANUAL

UL2 Front Mount

MODELS

4400 FM

6600 FM

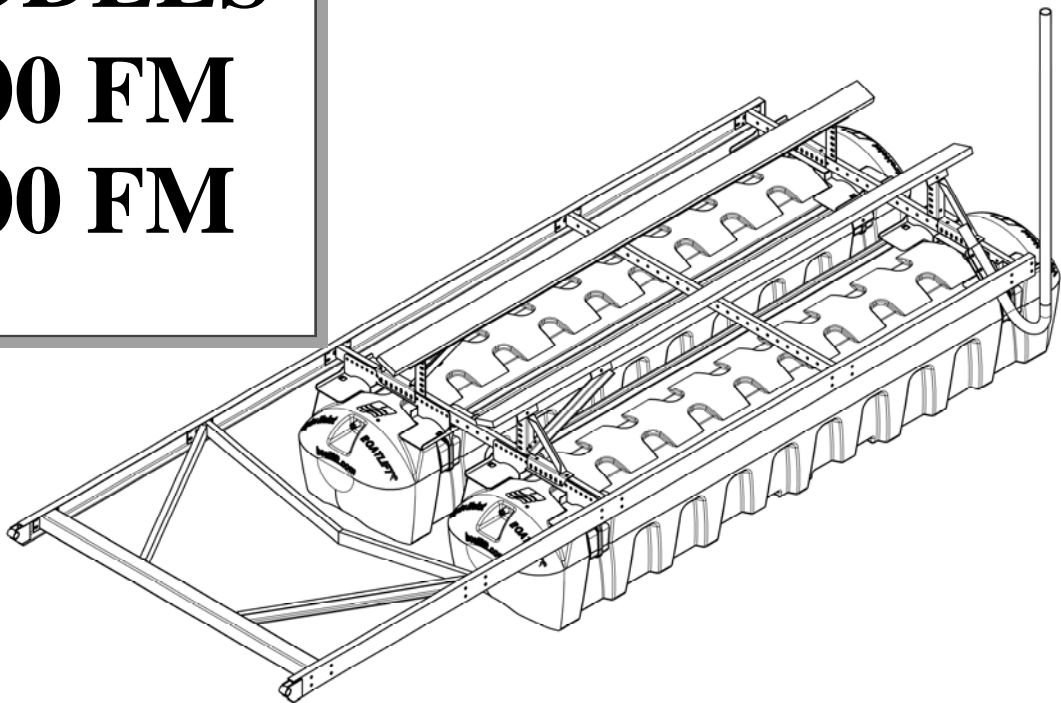

915 W. Blue Starr Dr. Claremore, OK 74017
(918)341-6811

HydroHoist® Marine Group Product Installation and Use Warning Disclaimer

ASSEMBLY, INSTALLATION OR REPAIRS OF A HYDROHOIST BOAT LIFT SHOULD ONLY BE PERFORMED BY AN AUTHORIZED HYDROHOIST TECHNICIAN. IF ASSEMBLY, INSTALLATION AND/OR REPAIR IS PERFORMED BY UNAUTHORIZED PERSONS, SERIOUS PERSONAL INJURY AND/OR PROPERTY DAMAGE COULD OCCUR.

IF UNAUTHORIZED PERSONNEL ASSEMBLE, INSTALL OR REPAIR A HYDROHOIST BOAT LIFT, HYDROHOIST MARINE GROUP HEREBY DISCLAIMS ANY AND ALL WARRANTIES, EXPRESS OR IMPLIED. HYDROHOIST MARINE GROUP LIMITS ITS WARRANTY TO HYDROHOIST MARINE GROUP'S PUBLISHED BOATLIFT WARRANTY FURNISHED WITH EACH PRODUCT. NO OTHER WARRANTY OF ANY KIND EITHER VERBALLY OR IMPLIED INCLUDING WARRANTIES OF MERCHANTABILITY AND FITNESS FOR A PARTICULAR PURPOSE ARE RECOGNIZED.

THE CONTENTS OF THIS MANUAL ARE SUBJECT TO CHANGE WITHOUT NOTICE AND SHOULD NOT BE CONSTRUED AS A COMMITMENT, REPRESENTATION, WARRANTY OR GUARANTEE OF ANY METHOD, PRODUCT OR DEVICE BY HYDROHOIST MARINE GROUP.

REPRODUCTION OR TRANSLATION OF ANY PART OF THIS MANUAL, WITHOUT THE WRITTEN PERMISSION OF HYDROHOIST MARINE GROUP IS PROHIBITED.

ANY INQUIRIES CONCERNING HYDROHOIST MARINE GROUP'S PUBLISHED WARRANTY OR THIS MANUAL AND ITS CONTENTS SHOULD BE REFERRED TO:

CUSTOMER SERVICE
HYDROHOIST MARINE GROUP
915 WEST BLUE STARR DRIVE
CLAREMORE, OK USA 74017
PHONE 918-341-6811
OFFICE HOURS M-F 8AM TO 5PM CT

HydroHoist® Marine Group Safety Notice

TO ENSURE CONSUMER SAFETY, HYDROHOIST MARINE GROUP HAS INSTALLED IN THE CONTROL UNIT'S ELECTRICAL SYSTEM AN AC GROUND FAULT CIRCUIT INTERRUPTER (GFCI) DEVICE WHICH IS TO BE USED IN SERIES WITH THE USER'S PRIMARY AC POWER SOURCE. THE GFCI IS AN INTEGRAL PART OF THE HYDROHOIST BOAT LIFT AND IS DESIGNED TO OFFER A LIMITED MEASURE OF PROTECTION TO THE USER AGAINST HAZARDOUS ELECTRICAL CONDITIONS OR SHOCKS SHOULD THEY OCCUR.

THE USER SHOULD BE AWARE OF THE FOLLOWING WARNING:

WARNING!

IF USER DISABLES THE CONTROL UNIT'S GROUND FAULT CIRCUIT INTERRUPTER (GFCI) DEVICE, HE IS IN DIRECT CONFLICT WITH THE RECOMMENDATIONS OF THE UNITED STATES GOVERNMENT CONSUMER PRODUCTS SAFETY COMMISSION. DISABLING THE GFCI COULD RESULT IN SEVERE ELECTRICAL SHOCK OR DEATH.

BEFORE CONNECTING AC POWER TO THE CONTROL UNIT, BE CERTAIN THAT THE PRIMARY AC POWER SUPPLY MEETS ALL APPLICABLE ELECTRICAL CODES.

ANY INQUIRIES CONCERNING THE GROUND FAULT CIRCUIT INTERRUPTER (GFCI) DEVICE SHOULD BE REFERRED TO:

CUSTOMER SERVICE
HYDROHOIST MARINE GROUP
915 WEST BLUE STARR DRIVE
CLAREMORE, OK USA 74017
PHONE 918-341-6811
OFFICE HOURS M-F 8AM TO 5PM CT

CONTENTS

Getting Started - *Section 1*

Site Preparation - *Section 2*

Assembly - *Section 3*

Installation - *Section 4*

Final Adjustments - *Section 5*

Trouble Shooting - *Section 6*

Parts List - *Section 7*

Getting Started

Assembly Platform

Assembly should be done on a flat, level surface.

A flat-bed trailer is preferred, but a boat trailer with planks across the frame will work, provided that the assembly surface is flat and level

Tools

A list of tools needed for hoist assembly is given below. In addition to these, tools for boat dock preparation, dock bumper removal, etc. may also be required.

- ◆ 1/2" Drive Ratchet (minimum 9 inch handle length for leverage)
- ◆ Electric Drill
- ◆ 3/4" Deep Well Socket
- ◆ 9/16" Deep Well Socket
- ◆ (2) 15/16" Open-end or Combination Wrenches
- ◆ 3/4" Open-end or Combination Wrenches
- ◆ 9/16" Open-ended or Combination Wrenches
- ◆ 5/16" Hex Wrench or Hex Tool Socket
- ◆ 5/16" Nut Runner or medium blade Slotted Screwdriver
- ◆ Medium Phillips Screwdriver
- ◆ Drift Pin or other hole aligning tool
- ◆ Large Hammer (3 or 4 lb. shop hammer is best)
- ◆ Knife or tool for cutting 1 1/4" rubber hose
- ◆ Measuring Tape
- ◆ 3/4" Ratcheting Open-end wrench

Symbols & Conventions

All references to the LEFT or RIGHT are considered to be facing forward, as if driving a boat into the slip. Left is Port side, Right is Starboard side.

Parts are occasionally described as LEFT or RIGHT to identify their opposing construction, not location on the hoist.

All numbers in brackets [] after part names refer to the item numbers on the assembly illustrations within the manual.

Site Preparation

Verify	The Boat Stall or Mooring Location. <ul style="list-style-type: none">◆ If the hoist is being installed in a commercial marina or multi-slip boat dock, confirm the correct mooring location for hoist and boat.
	The boat specifications. <ul style="list-style-type: none">◆ Make _____◆ Model _____◆ Length _____◆ Beam _____◆ Dry Weight of boat _____ lbs.◆ Fuel: _____ gal. @ 6.6 lbs./gal. = _____ lbs.◆ Water: _____ gal. @ 7.5 lbs./gal. = _____ lbs.◆ Gear estimated @ 8% of boat's dry weight _____ lbs.◆ Other equipment or weight _____ lbs.◆ TOTAL LIFTING WEIGHT _____ LBS.

Inspect	The boat slip, dock or seawall to which the hoist will be installed.
	◆ The structure should be of good, sturdy construction capable of maintaining a secure mooring for the hoist.
	◆ The Dock Brackets, which will be mounted on the dock to provide hoist mooring, have a minimum gripping distance of 5 inches and a maximum gripping distance of 19 inches. Confirm that there is sufficient dock structure for the Dock Brackets.
	◆ The HydroHoist 4000FM requires a minimum of 7 feet , the 6000FM requires a minimum of 7 feet 9 inches of water depth in which to operate. Confirm that there is sufficient water depth at all times of the year.
	◆ Check for underwater obstructions, such as structural braces, cables, rocks, or sunken objects which will interfere with the hoist's operation.
	◆ Check for overhead obstructions and confirm that sufficient clearance exists for the lifting of the boat.
	◆ Confirm that electrical supply is available and sufficient for hoist operation.
	◆ Confirm that sufficient dock space is available for mooring the hoist and boat.
	◆ CONFIRM THE BOAT LENGTH - Boats with a center line length longer than 24 feet should not be installed on the 4000 FM. Boats with a center line length longer than 26 feet should not be installed on the 6000 FM.

Assembly Instructions

Description The assembly instructions presented within this section represent the steps for assembling the Model 4400FM & 6600FM HydroHoist Boat Lift. It is recommended that before assembling the components, you read and understand each procedural step to become familiar with how all parts are assembled.

Tightening of Fasteners In the assembly procedures, DO NOT TIGHTEN fasteners until directed to do so. Insert bolts with appropriate washers, lock washers and nuts, but, unless otherwise instructed, leave the fasteners loose to allow movement of the parts for adjustment during assembly.



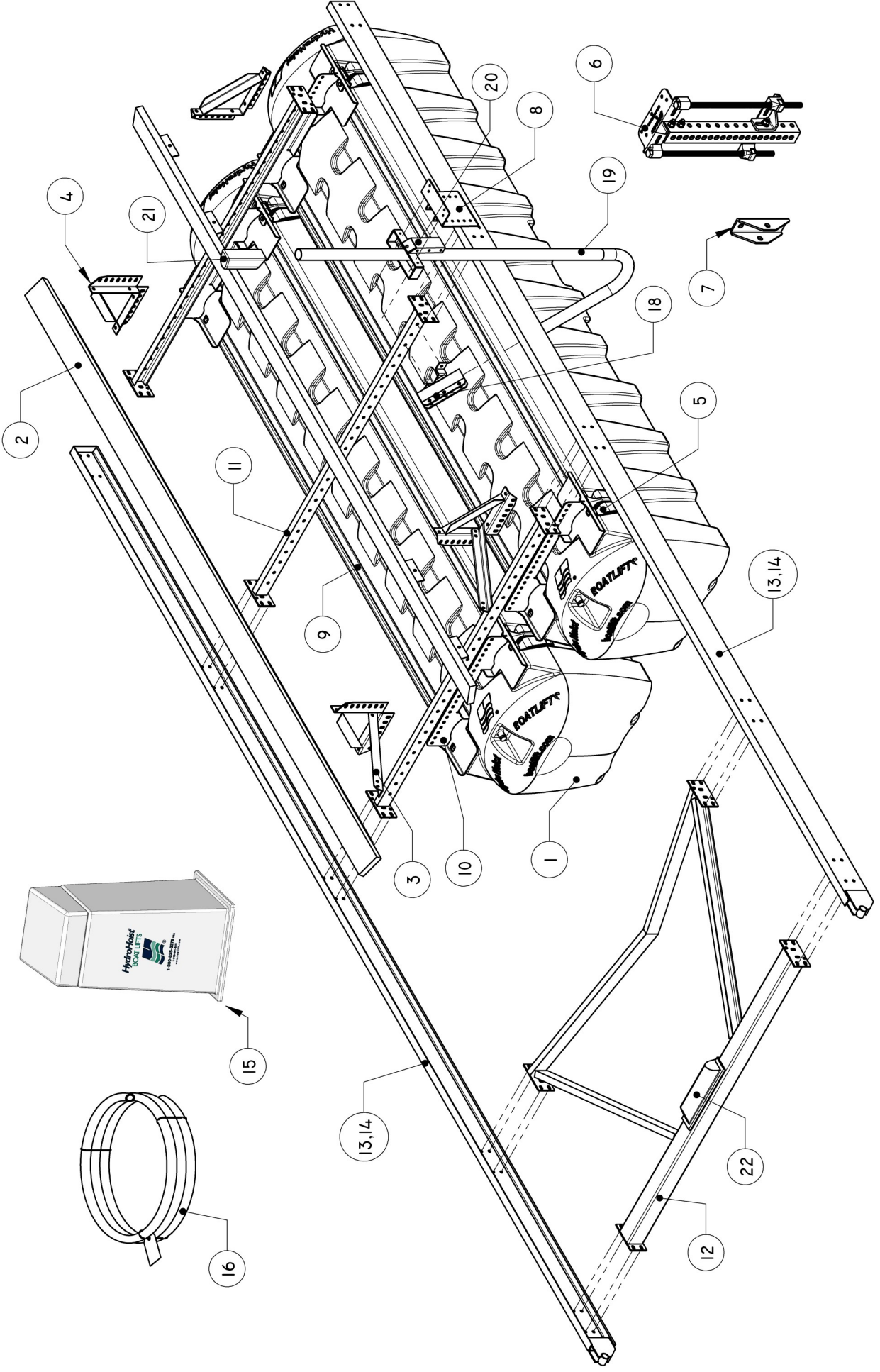

Tank Location
Fig. B

Step	Procedure
1.1	Align the Tanks [1] parallel with each other and with the Air Injection Nipple to the front of the hoist assembly and in the 6 o'clock position.

Fig. B

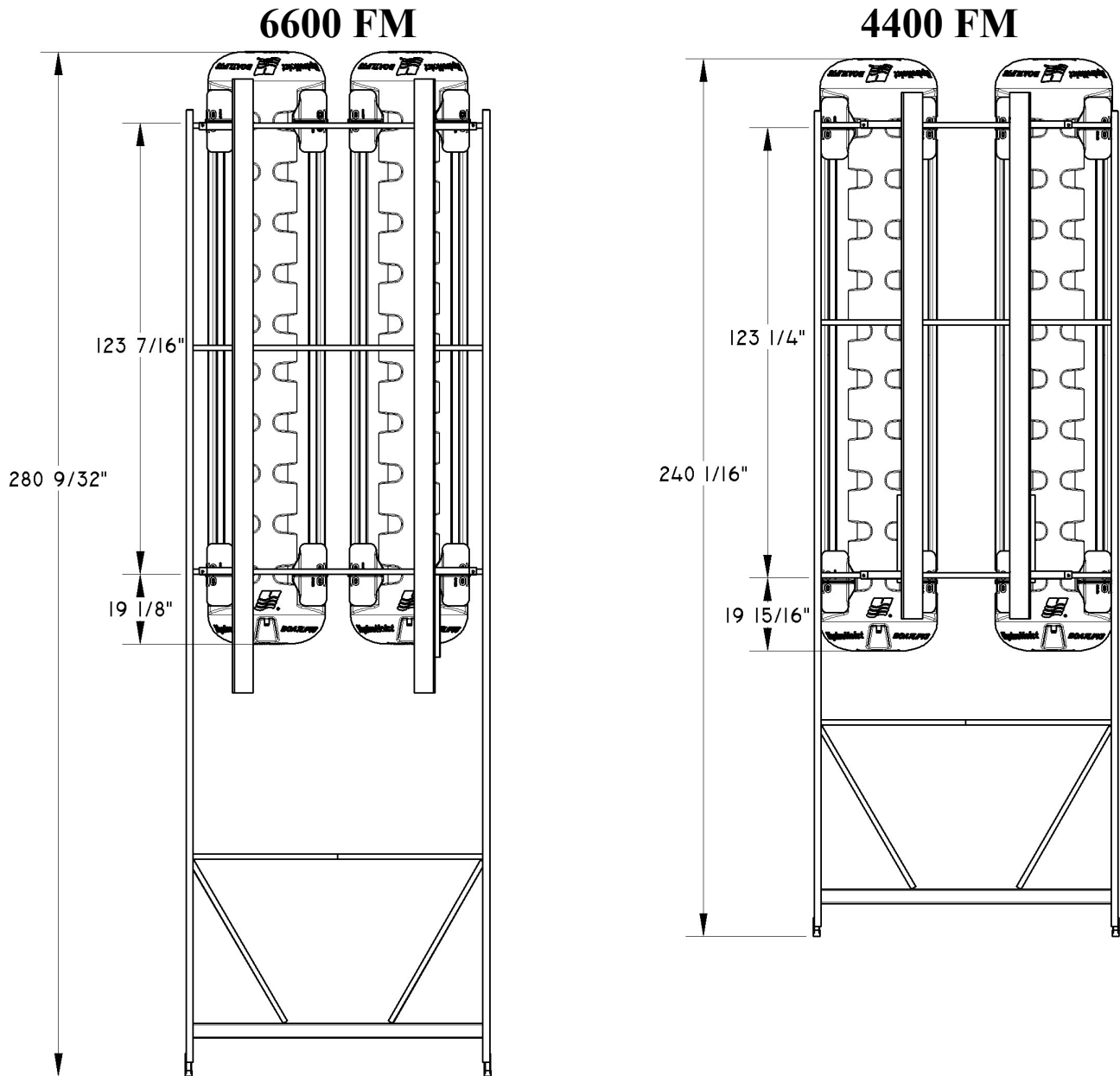

Tank Bracket Assembly

Fig. B

Step	Procedure
2.1 <i>Fig B</i>	Place the tube brackets [9] in the longitudinal channels which span the top of the tanks.

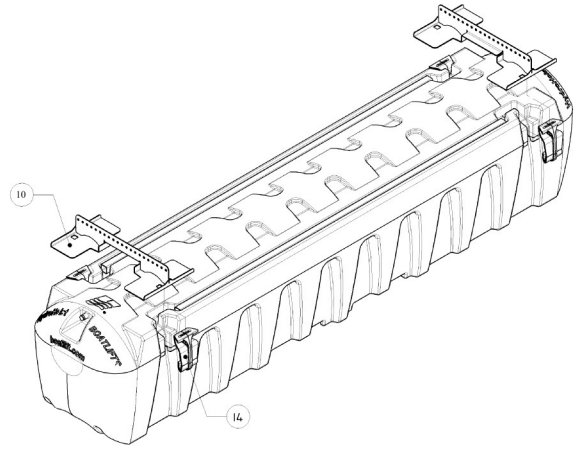
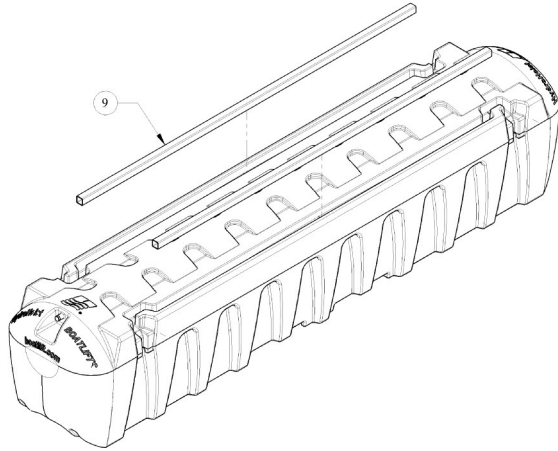

Step	Procedure
1.2 <i>Fig C</i>	Snap the UL2 side brackets [14] into place, followed by placing the Single Piece Tank Bracket [10] on top of the side bracket and attaching with fasteners. Fasteners per single piece/plastic bracket: (2ea.) 1/2" X 2 1/2" Hex Head bolts, nuts, and lock washers. (4ea.) 1/2" Flat Washers.

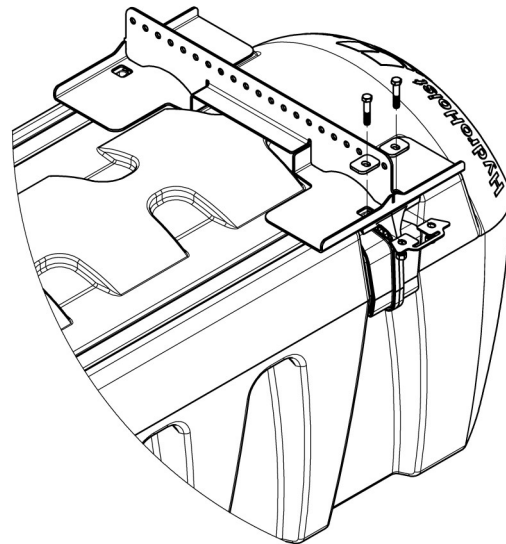
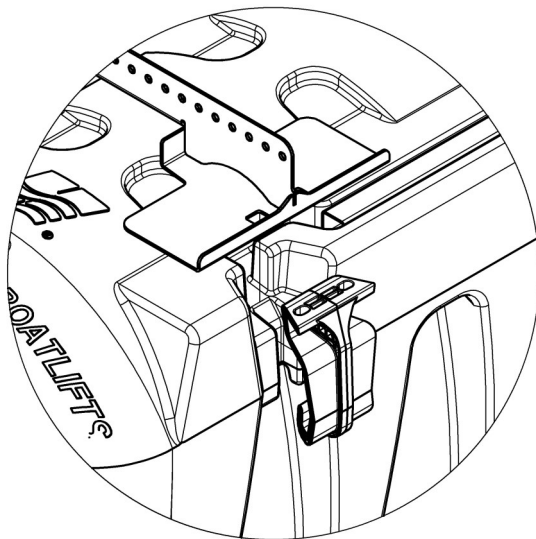

Channel Assembly
 Fig. E

Step	Procedure
3.1	Attach front and rear Cross Channel [11] to Single Piece Tank Brackets[10]. <i>Note:</i> Position Cross Channel [11] with flanges of Channel to rear of hoist. Fasteners per Upper Tank Band: (4 ea.) 1/2" x 1-1/2" bolt, nut & lockwasher.
3.2	Attach Side Channels [13,14] with flanges of Channel facing inboard and square end to rear, to Cross Channels [11] Fasteners per Channel: (8 ea.) 1/2" x 1-1/2" bolt, nut & lockwasher with flatwasher on slotted holes. <i>Tip:</i> For assembly by one person - A) Lift the rear of the Side Channel [14] into position and temporarily secure it with a 1/2" x 5" bolt (found in parts bag). B) Raise the front of the Side Channel and attach it loosely to the front cross Channel [11] using 1/2" x 1-1/2" bolts. C) Return to the rear of the Side Channel, remove the 5" bolt, and secure using 1/2" x 1-1/2" bolts
3.3	Attach center Cross Channel [11] to Side Channels [13,14] Fasteners per Cross Channel: (8 ea.) 1/2" x 1-1/2" bolt, nut & lockwasher with flatwasher on slotted holes.

Fig. E

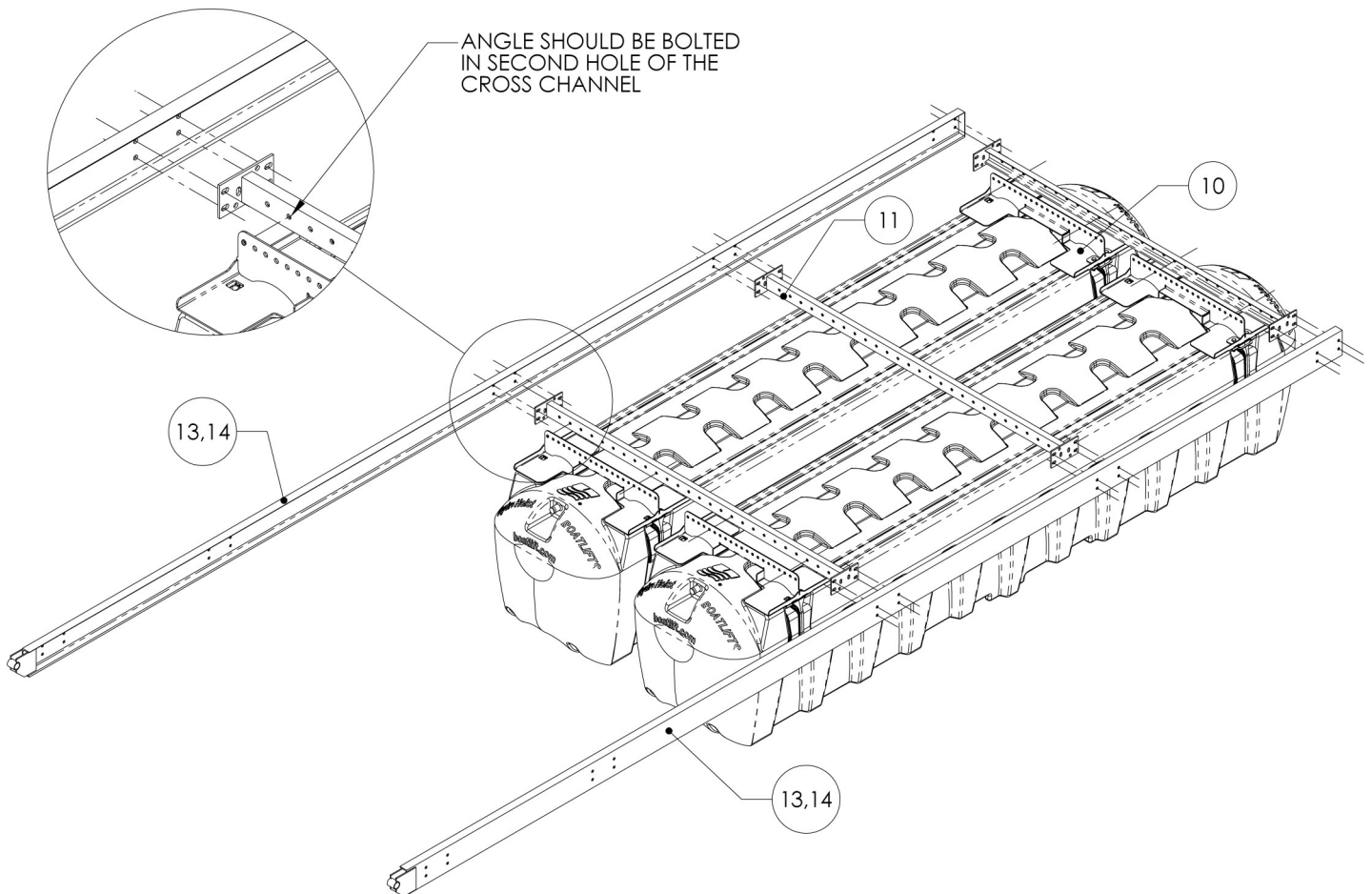

Note... The parts installed in the next steps may have to be moved to better fit the bottom of the boat after it has been lifted. Accurate measurements of the boat's hull before assembly and careful attention to these steps may prevent repositioning the parts over the water.

Positioning... If the boat hull is unable to be measured prior to hoist assembly, space the Hull Support Columns [4] 36" to 42" apart at the rear of the hoist, and the front columns 3" narrower than the rear. Typically, the longer leg of the column [4] is positioned vertically to lift the boat higher above the water, however the shorter leg of the column may be positioned vertically to accommodate a boat with a deeper draft.

Hull Support Assembly
 Fig. F

Step	Procedure
4.1	Attach two Hull Support Columns [4] to the front Cross Channel [11] and two Hull Support Columns to the rear Cross Channel [11]. Attach the columns with the flat side of the angles facing to the front of the hoist assembly, and the brace angle of the column outboard. Fasteners per Column: (2 ea.) 1/2" x 1-1/2" bolt, nut & lockwasher.
4.2	Attach Hull Support Pads [2] to the tops of the front and rear Hull Support Columns [4]. The pad's long angle iron frame member should be <i>inboard</i> so that its weight keeps the pad tilted inboard, toward the boat hull. Fasteners per Pad: (2 ea.) 1/2" x 5" bolt, nut & lockwasher.
4.3	Install the Hull Support Pad Braces [3] between the Hull Support Pads [2] and the Hull Support Columns [4]. <i>The flat side of the braces face inboard.</i> Fasteners per Brace: (1 ea.) 1/2" x 1-1/2" bolt, nut & lockwasher at Column; (1ea) 1/2" x 5" bolt, nut & lockwasher at Hull Support Pad.
4.4	Tighten the 5" Hull Support Pad bolts only enough to flatten the lockwashers. Do not tighten any other bolts at this time.

Fig. F

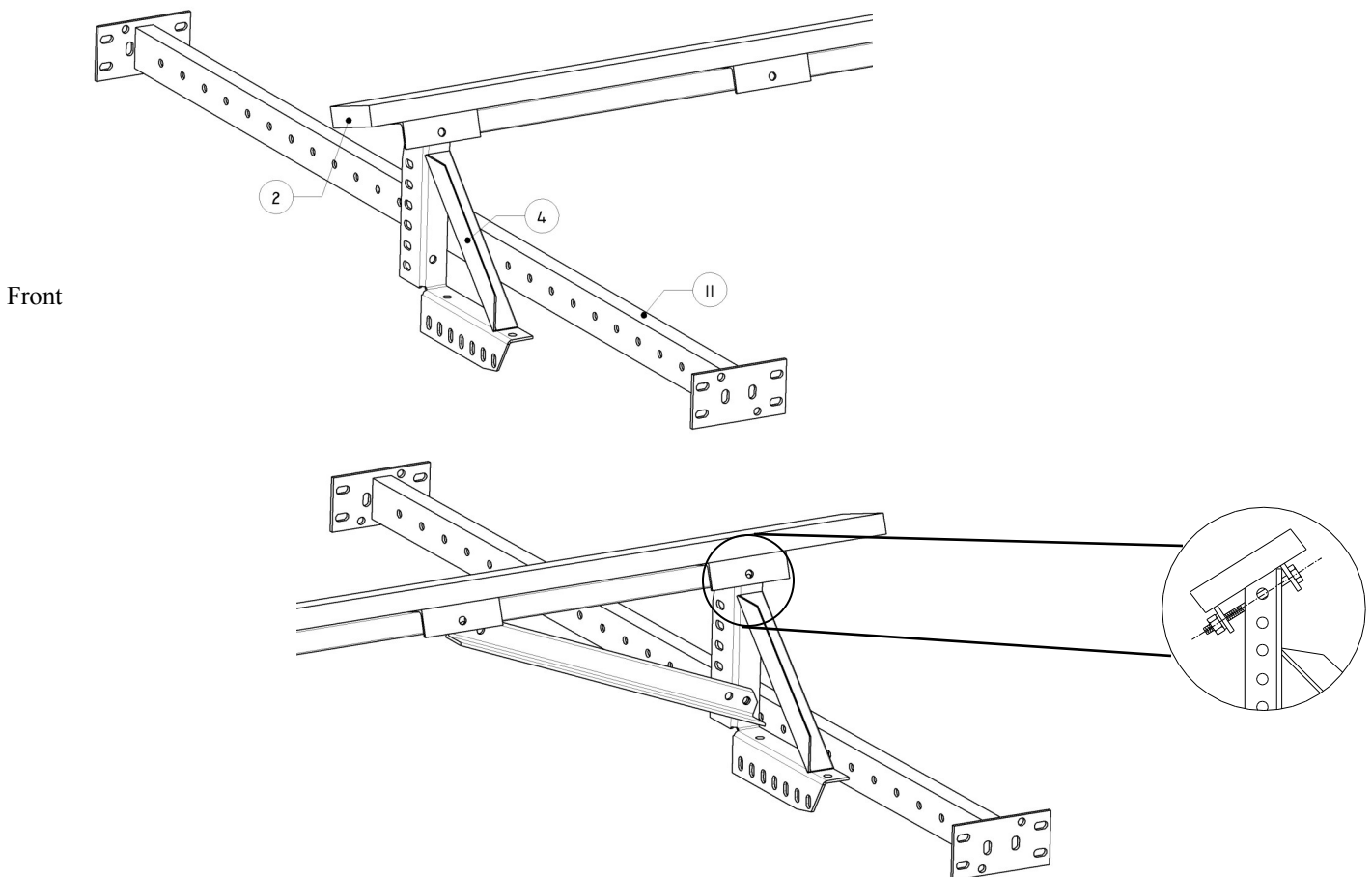

Frame Weldment Assembly
Fig. G

Step	Procedure
5.1	Under the Frame Sections [13 & 14] suspend by rope or chain, a 2 X 4 X 8 foot board as shown in Fig. G
5.2	With the "Square Tube Section" of the Frame Weldment Assembly [12] still on the ground, lift the "Drop V" Section of the Weldment Assembly [12] and place on top of the 2x4 board and in position to (later) be bolted to the frame.
5.3	Using a come-a-long attached at the front pivots, draw the Side Channels [13 & 14] together as you raise the "Square Tube Section" of the Weldment Assembly [12] into the bolting position, and loosely attach the "Square Tube Section" [12] to the Side Channels. Fasteners per side: (4 ea.) 1/2" x 1-1/2" bolt, nut lockwasher and flatwasher on slotted holes.
5.4	Attach the "Drop V" Section of the Frame Weldment Assembly [12] to the Side Channels [13 & 14]. Fasteners per side: (4 ea.) 1/2" x 1-1/2" bolt, nut lockwasher and flatwasher on slotted holes.

Fig. G

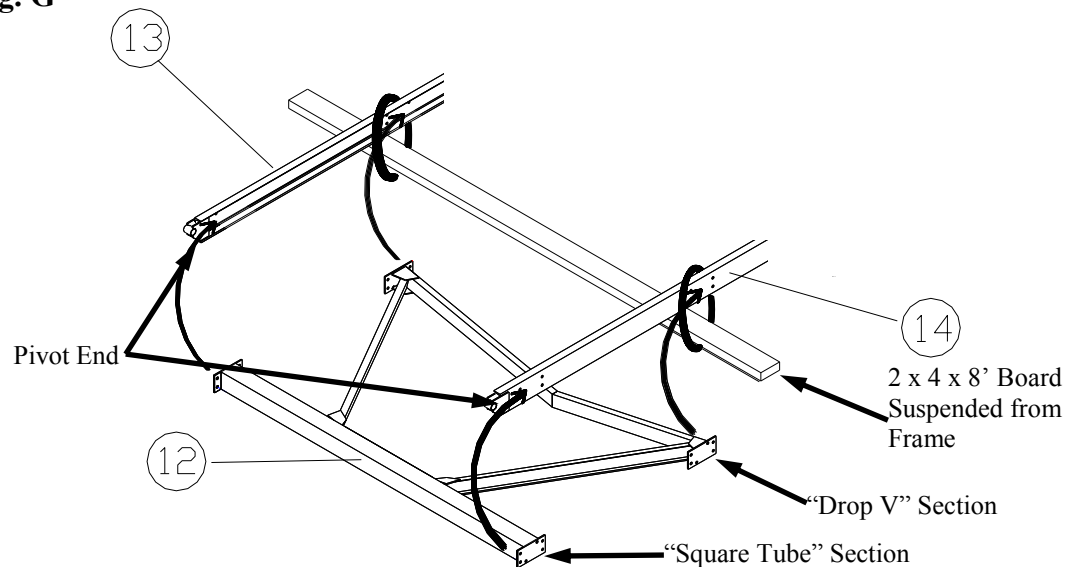

Leveling the Hoist

Step	Procedure
6.1	Stand at the rear of the hoist and sight from the <i>rear</i> Cross Channel [11] to the <i>front</i> Cross Channel to make sure the front and rear are parallel and that there is no twist or warp in the hoist. If one corner appears to be low, place a block under that corner, as necessary, to align the corners.
6.2	Stand at the side of the hoist and sight across the Side Channels [13 & 14] to make sure that they are parallel and that there is no twist or warp in the hoist. If one corner appears to be low, place a block under that corner, as necessary, to align the corners.
6.3	With the Unit Level Tighten all 1/2" bolts to approximately 65 ft.-lbs. of torque. <i>Exception: The 5" Hull Support bolts previously tightened. Note: When tightening bolts on the frame, the end plates of the Cross Channels and Weldment Assembly MUST be against the web of the side Channel - NO GAP should exist between the parts.</i>

Tightening All Fasteners

Mooring Tube
Fig. H

Step	Procedure
7.1	Determine the location of the Mooring Tube Assembly: FM 4400 - the <i>rear</i> Cross Channel [11] is preferred, the <i>center</i> Cross Channel is optional. FM 6600 - the <i>center</i> Cross Channel [11] is mandatory.
7.2	Attach Mooring Pipe Clamp [18] to Cross Channel [11]. Fasteners: (4 ea.) 1/2" x 1-1/2" bolt, nut & lockwasher. Tighten these bolts at this time.
7.3	Insert short end of Mooring Pipe [19] into Mooring Pipe Clamp [18]. Adjustment: <i>The distance from the center of the hoist to the inboard side of the Mooring Pipe [19] should equal 1/2 of the boat's beam plus 1 to 2 inches.</i>
7.4	With the Mooring Pipe [19] properly positioned and vertical, tighten the bolts on the Mooring Pipe Clamp [18]. Fasteners: (3 ea.) 1/2" x 2" bolt, nut & lockwasher.

Fig. H

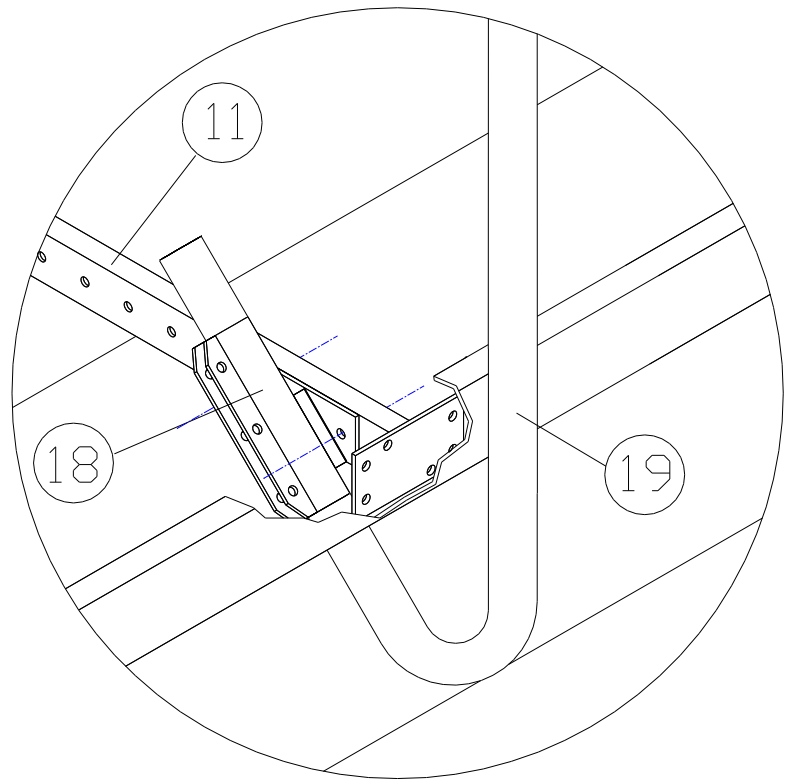

Front Bumper

Step	Procedure
8.1	Attach Bumper [22] to Frame Weldment [12]. Fasteners: (4 ea.) Screws, self drilling self tapping #12 x 7/8".

Hose Assembly

Step	Procedure
9.1	Cut Hose [16] in half and secure one end of each hose to the nipple of the tank and one end to the valve in the control. Secure with Hose Clamps.

Launching the Hoist

Step	Procedure
10.1	Secure the Control Unit [15] to a Hull Support Column [4] in the front of the Hoist. Make sure that all valves are closed in the "Dry-Dock" position.
10.2	Insert Tank Plugs (Pt. No. 2905406) into the 6" Water Discharge Hole of EACH Tank. Note: DO NOT tow without Tank Plugs.
10.3	FM 4000 - Secure additional flotation, such as a block of Styrofoam, under the Frame Weldment Assembly [22] - the flotation must be sufficient to prevent the hoist from tipping forward when launched and towed. <i>Note: The FM 6000 does not require additional flotation, but flotation may be used to stabilize the hoist in difficult towing environments.</i>
10.4	Attach a towing line to the rear Cross Channel of the hoist.
10.5	Back the trailer into the water to float the hoist. <i>Do this SLOWLY so that the front of the hoist or Tanks will not pivot hard into the trailer.</i>
10.6	Slowly tow the hoist to its mooring location.

Selecting Position for Hoist

Fig. I

Step	Procedure
1.1	Move the hoist fully into the boat stall and position the Mooring Tube [19] 2 inches from the side of the dock.
1.2	With the hoist held in the proper position, place a mark on the dock at TWO points: 1-The location of the Pivot Bushing of the left/port Side Channel [14]. 2-The position of the Pivot Bushing of the right/starboard Side Channel [13].

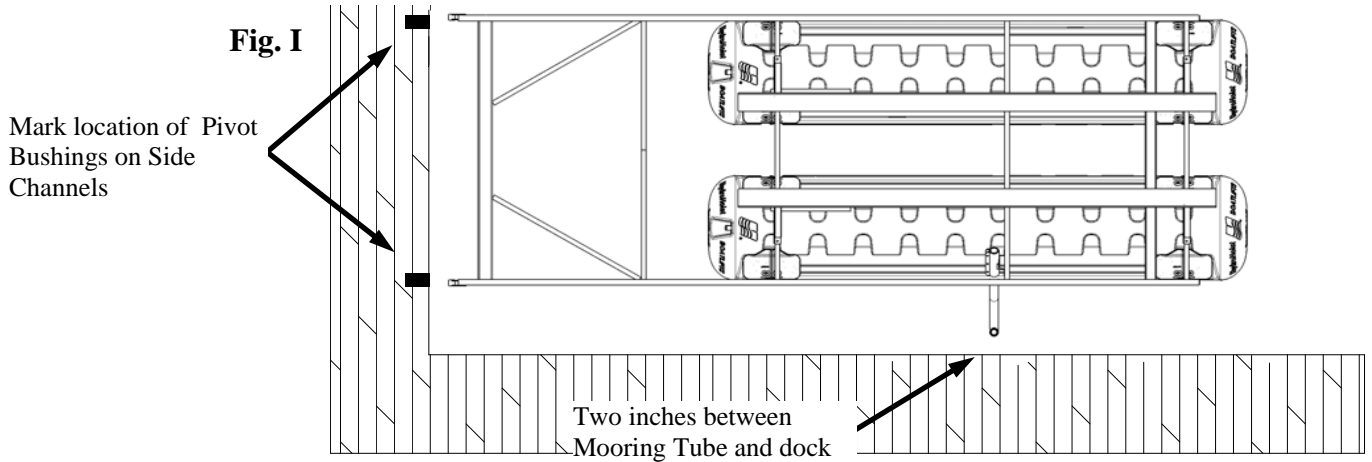

Front Dock Bracket

Figs. I&J

Step	Procedure
2.1	Attach Dock Brackets with the holes of the Vertical Angle [32] aligned with the mark on the dock locating the position of the Pivot Bushings. Note: Grip Tabs [33] must be installed to reduce movement of the Lower Dock Bracket Angle [30]. If Grip Tabs are not applicable, it will be necessary to (later) through-bolt the Dock Bracket to the dock structure to eliminate movement. Fasteners: 2 Grip Tabs per Dock Bracket - 2 ea 1/2" x 1" Carriage Bolt & nut.
2.2	Loosely tighten the 20" Dock Bracket Bolts [31]. <i>It may be necessary to slightly adjust the position of the Dock Brackets when attaching the hoist.</i>

Fig. J

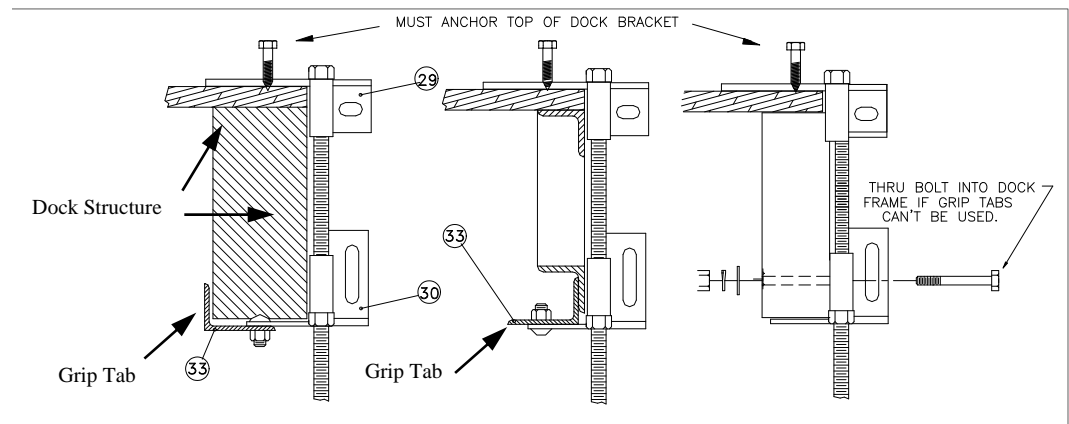
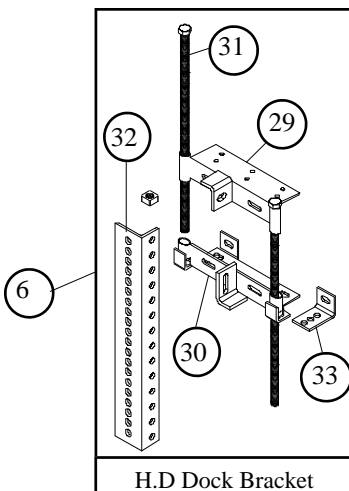

**Front Mooring
 Attachment**
Fig. K

Step	Procedure
3.1	Attach Pivot Connecting Bracket [7], with the pivot hole 10 inches above the water line , to Vertical Angle [32] . Fasteners per Bracket: (2 ea.) 1/2" x 1-1/2" bolt, nut & lockwasher. Tighten these fasteners at this time to 40 ft-lbs.
3.2	Attach Side Supports [13-14] to Pivot Connecting Brackets [7] using Bushings [23-24] and Fasteners: (1 ea per Bracket) 5/8" x 3-1/2" Bolt, nut and lockwasher. <i>Note: It may be necessary to adjust the lateral position of the Dock Bracket to accomplish attachment of the Side Supports to the Connecting Brackets.</i>
3.3	With hoist attached to Dock Brackets, check the distance between the side of the dock and the Mooring Pipe [19]. This distance should be 2 inches. <i>If greater or less than 2 inches, adjust the lateral position of the Dock Brackets to accomplish the 2 inch distance..</i>
3.4	With the hoist in the proper position, tighten the 20" Dock Bracket Bolts [31] to about 35 ft-lbs of torque.

Fig. K

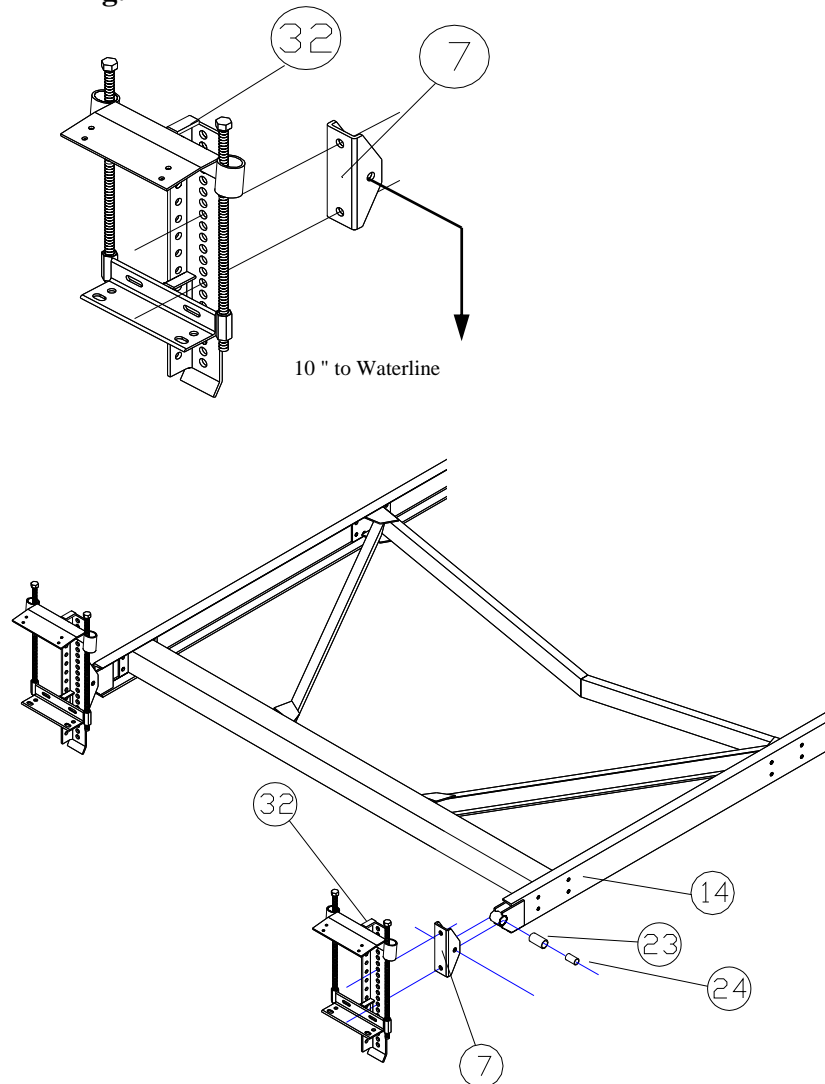

Side Mooring Attachment
Fig. L&M

Step	Procedure
4.1	Assemble Mooring Collar Assembly [20] to Side Dock Bracket [8]. Fasteners: (2 ea.) 3/8" x 4-1/2" Bolt, Nut and Lockwasher. <i>Note: The Collar Assembly may be positioned high or low, by attaching to the Dock Bracket with either the Center and Top holes, or Center and Bottom holes. The Collar Assembly can also be inverted, allowing the Collar to be positioned lower on the Dock Bracket to accommodate decks high above the water.</i>
4.2	Slide the assembled Mooring Collar and Dock Bracket [20 & 8] over the Mooring Pipe [19]. Position the assembly so that the Mooring Pipe [19] is to the FORWARD END of the Mooring Color Slide. <i>Note: As the hoist lowers, the Mooring Pipe will pivot to stern - ample travel distance is provided in the Mooring Collar, provided the Mooring Pipe is installed to the forward end when the hoist is raised.</i>
4.3	Secure the Side Dock Bracket [8] to the dock using Lag Bolts or appropriate fasteners.

Fig. L

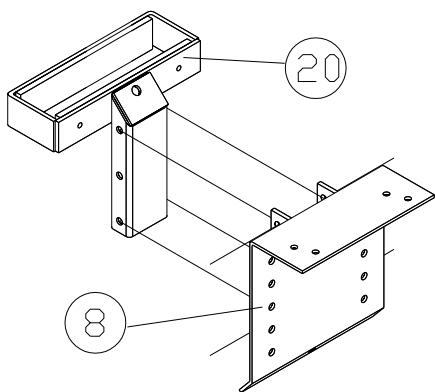
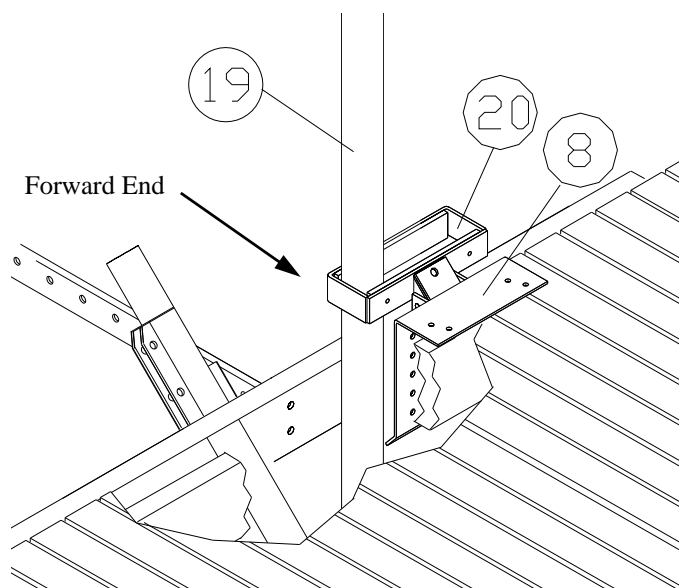

Fig. M



Catch Chain

Control Unit

Final Details

Step	Procedure
5.1	Make a small loop of Catch Chain around Side Support [13/14] in the area of the Mooring Pipe. Secure the loop with Fasteners: (1 ea) 3/8" x 2-1/4 bolt, (2) nuts and (2) flatwashers. (Double nut / double flatwashers).
5.2	Extend approximately 5 feet of chain from the Side Support to the Side Dock Bracket, and attach the Catch Chain to the Side Dock Bracket. Fasteners: 3/8" x 2-1/4" bolt, nut and flatwasher.
5.3	Mount Control Unit [15] securely to deck in the desired location.
5.4	Connect the power cord to proper power source and test the motor switch to ensure operation. <i>Note: It may be necessary to reset the GFCI switch upon first operation.</i>
5.5	TIGHTEN ALL FASTENERS, DOCK BRACKETS, & FIXTURES.
5.6	REMOVE ALL TANK PLUGS.

Lowering the Hoist

Step	Procedure
6.1	Rotate the Control Unit Handle to the Lift/Launch position. <i>Note: It may be necessary to turn blower on for three or four seconds to purge any water trapped in the air hoses; additionally, without the weight of the boat, air will exhaust slowly from the tanks.</i>
6.2	With the hoist in the fully lowered position, test the Catch Chain length - the front ends of the Hull Support Pads [2] should be at or just below the water. Adjust the Catch Chains accordingly.
6.3	With the Catch Chain correctly adjusted, install the Bumper [21] onto the top of the Mooring Pipe and attach with self drilling screws. Fasteners: (2 ea.) #12-24 x 7/8".

Positioning the Boat for Lifting

Step	Procedure
7.1	Pull the boat over the hoist and position the boat's fore/aft Center of Gravity directly over the CENTER Cross Channel [11] of the hoist frame. <i>(The object is to balance the boat on the Hoist. Bow heavy position places excessive stress on pivots and moorings. Stern heavy position inhibits proper lifting.)</i> Note: Boats with a center line length longer than 24 feet should not be installed on the 4000 FM. Boats with a center line length longer than 26 feet should not be installed on the 6000 FM.
7.2	With the boat in the proper position, and centered port & starboard over the lift, secure Guide Ropes: <ol style="list-style-type: none"> 1. Tie a small loop (about 6 inches in diameter) in one end of each Guide Rope and place the loops over the REAR port & starboard cleats of the boat. 2. Pull the Guide Ropes tight and tie the loose ends to the outboard ends of the Frame Weldment Assembly [12]. 3. Attach the Warning Decals (SP34) to the Guide ropes.

Fig. N

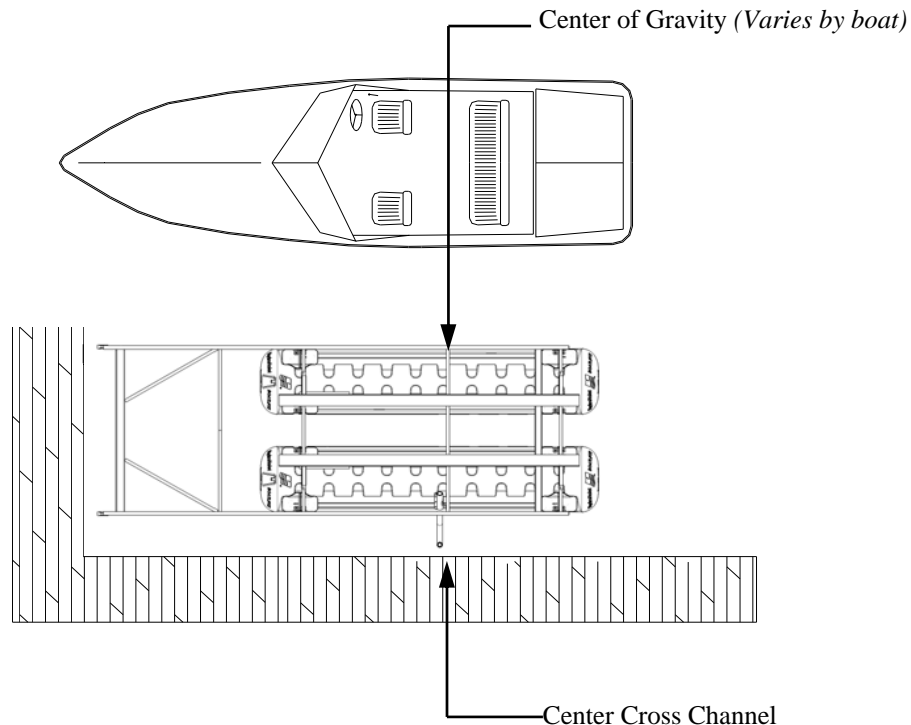

Lifting the Boat

Balance and Load

Step	Procedure
7.3	Hold the front of the boat centered over the hoist, pushing the boat to stern gently until the Guide Ropes are taut. <i>The Guide Ropes center the boat's stern over the hoist, and keep the transom aligned over the Hull Support Pads.</i>
7.4	While continuing to push back gently on the boat and keeping the Guide Ropes taut, rotate the Control Unit Handle to the Lift/Launch position and turn the switch to ON. <i>When the hoist makes full contact with the boat, it is no longer necessary to push back on the boat.</i>
7.5	As the hoist raises, observe the hoist's operation; the position of the boat on the Hull Support Pads; Moorings and Dock Brackets, and the Guide Ropes. STOP, LOWER THE HOIST, AND MAKE ADJUSTMENTS IF NECESSARY.
7.6	With the hoist fully raised, carefully observe the boat's position on the hoist and on the Hull Support Pads. The boat should be centered side to side, with the hull Support Pads contacting the hull between the chines and to the transom area. Note 1: It is common for some unavoidable crossing of the chines at the bow of the boat, which is acceptable. Note 2: The ends of the Hull Support Pads should extend to the transom of outboard boats; for stern-drive boats, the ends of the Hull Support Pads should not extend forward of the engine compartment. Reposition the boat or pads if necessary.
7.7	Carefully check the hoist's position in the water. The tanks should be level fore to aft with an acceptable 4 inch drop to stern. Correct the fore to aft position of the boat on the hoist to correct any imbalance.
7.8	At least 6 inches of each tank should be above the water surface for correct lifting and hoist stability. If less than 6 inches of the tank is above the water, the boat is too heavy for the hoist, and a larger hoist should be installed.

Final Adjustments

Final Inspection

Step	Procedure
1.1	Operate the hoist again - launch then lift - checking for proper positioning of the boat and Pads, and for proper operation of the lift, and Moorings.

Wrapping Up

- ◆ Loosely, secure a bow line to the boat and to the boat dock.
- ◆ Confirm that the operating Instructions are in the Control Unit.
- ◆ Unplug the power cord and stow it in a secure position.
- ◆ Complete the Warranty information and apply the adhesive Serial Number Tag to the Top Plate of the Control Unit.
- ◆ Close and secure the Control Unit Lid.
- ◆ Whenever possible, instruct the boat owner in the proper operating procedures of the hoist.

CAUTION: DESTRUCTIVE WIND OR WATER CONDITIONS

The HydroHoist Mooring Apparatus is not designed for destructive wind or water conditions. Should the potential for destructive conditions exist, it is recommended that mooring lines be secured from dock structure to bow and stern of craft to offer an additional measure of protection to the HydroHoist Mooring Apparatus and craft.

Trouble Shooting

CONDITION:	Hoist will not completely lift boat from water or stern remains low.
CAUSE:	A. Boat loaded too far to rear. B. Water or equipment in boat creating additional weight. C. Boat weight exceeds lifting capacity of hoist.
CORRECTION:	A. Reposition boat forward to balance weight over hoist and adjust the Guide Ropes to maintain proper positioning. B. Remove water or equipment. C. Install correct size hoist to accommodate the boat's true weight.
CONDITION:	Hoist tips side to side when lifting or launching.
CAUSE:	A. Restricted air flow to lifting tanks. B. Hoist is not square, frame is twisted.
CORRECTION:	A. Remove kinks or water-lock from hoses. B. Loosen Tank Bands, level hoist, and proper tighten Tank Bands.
CONDITION:	Hoist leaks down.
CAUSE:	A. Leak in valve, tank, or hose.
CORRECTION:	A. Locate leak and repair.
CONDITION:	Control Unit Blower not working.
CAUSE:	A. GFCI circuit open. B. Switch or Blower Motor malfunctioning. C. Power service to dock not on.
CORRECTION:	A. Reset GFCI switch. B. Replace Switch or Blower Motor. C. Turn on power service to dock.

Parts List 44/66 FM			FL44	FL66
1	5015500	TANK ASSEMBLY - UL2 4400	2	
	5015510	TANK ASSEMBLY - UL2 6600		2
2	4442000	PAD ASSY.-12' HULL SUPT.	2	
	5025600	PAD - HULL SUPPORT-14'		2
3	3031700	BRACE-HULL PAD-25 3/4 IN ANGLE	2	2
4	4031150	HULL SUPT COL UNIV	4	4
5	4210001	UL2 SIDE BRACKET - PLASTIC	8	8
6	5049000	DK BRKT- HVY DUTY	2	2
7	4440040	PIVOT - CONNECTING BRKT.	2	2
8	4440050	SIDE DOCK BRKT.	1	1
9	4220501	TANK TUBE 44/66 UL2 GATOR	4	4
10	4210070	TANK BRACKET -SINGLE - PIECE UL2	8	8
11	4440012	CROSS CHANNEL ASSY.	3	3
12	4440000	FRAME WELDMENT	1	1
13	4441200	SIDE SUPT.-ASSY - 44UL2	1	
	4441000	SUPT-SIDE-6" @ 260 1/2-NORM		1
14	4441300	SIDE SUPT.-ASSY - 44UL2	1	
	4441100	SUPT-SIDE-6" @ 260 1/2-OPP		1
15	5822005	CONTROL - 2V-1M - METAL MANIFO	1	1
16	3072512	HOSE-1 1/4" I.D. CUT 30' LG	1	1
18	4440020	MOORING CONNECTING PIPE ASSY.	1	1
19	4440034	MOORING PIPE ASSY.	1	1
20	4440054	MOORING TUBE COLLAR ASSY.	1	1
21	2914702	BUMPER - (J-TUBE)	1	1
22	2908400	BUMPER - STRAIGHT MOUNT 18" -	1	1
	6966400	KIT BOX-44/66 UL2 FM ULTRA	1	1

End of Section 7

End of Publication