

# INSTALLATION MANUAL *SHALLOW WATER*

MODEL  
6000

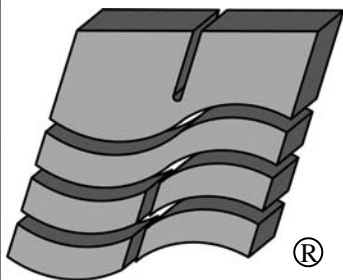
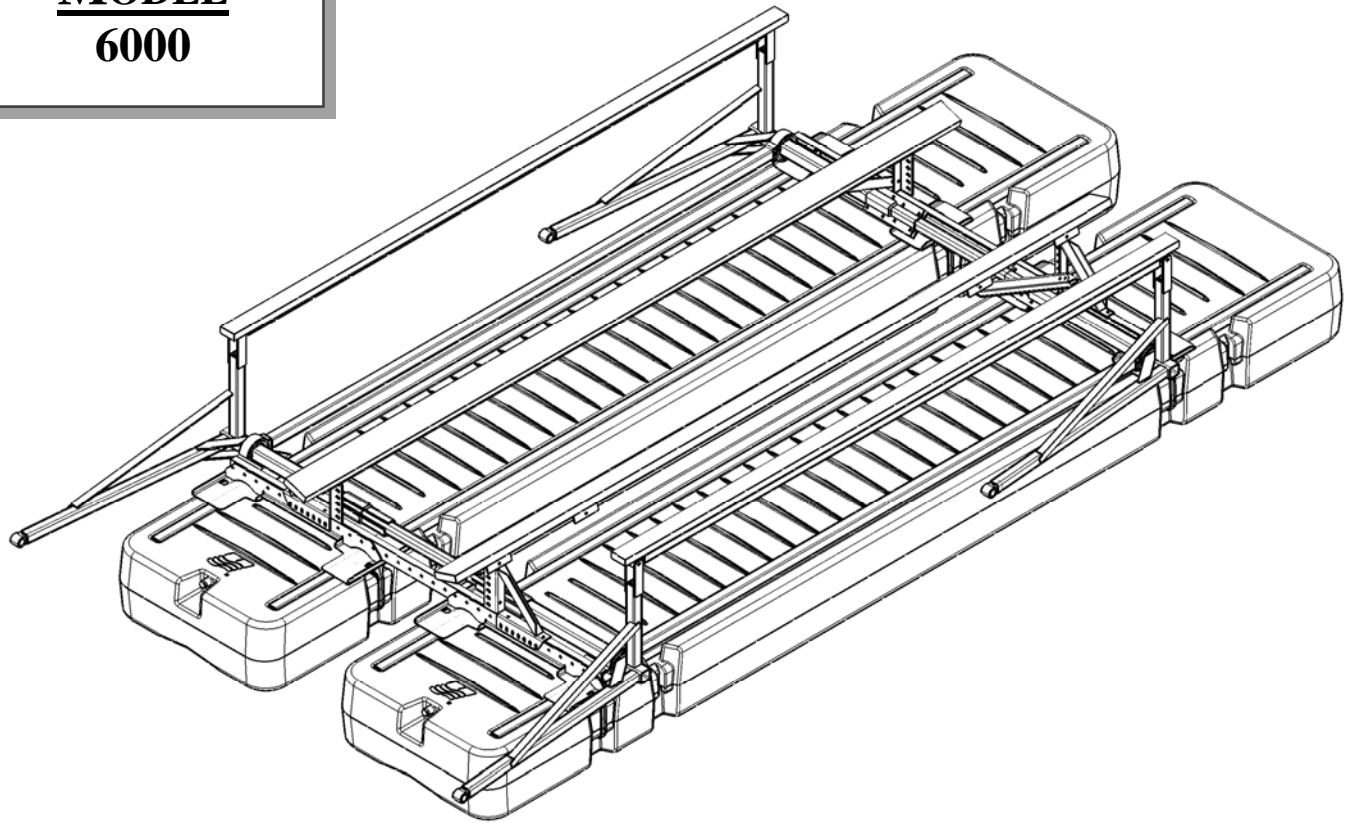

***HydroHoist***® ***Boat Lifts***

HydroHoist International, Inc.  
P.O. Box 1286 Claremore, OK USA 74018  
1-800-825-3379  
[www.boatlift.com](http://www.boatlift.com)

Pub. 08/28/07

## **HydroHoist International, Inc. Product Installation and Use Warning Disclaimer**

ASSEMBLY, INSTALLATION OR REPAIRS OF A HYDROHOIST BOAT LIFT SHOULD ONLY BE PERFORMED BY AN AUTHORIZED HYDROHOIST TECHNICIAN. IF ASSEMBLY, INSTALLATION AND/OR REPAIR IS PERFORMED BY UNAUTHORIZED PERSONS, SERIOUS PERSONAL INJURY AND/OR PROPERTY DAMAGE COULD OCCUR.

IF UNAUTHORIZED PERSONNEL ASSEMBLE, INSTALL OR REPAIR A HYDROHOIST BOAT LIFT, HYDROHOIST INTERNATIONAL, INC. HEREBY DISCLAIMS ANY AND ALL WARRANTIES, EXPRESS OR IMPLIED. HYDROHOIST INTERNATIONAL, INC., LIMITS ITS WARRANTY TO HYDROHOIST INTERNATIONAL INC.'S PUBLISHED BOATLIFT WARRANTY FURNISHED WITH EACH PRODUCT. NO OTHER WARRANTY OF ANY KIND EITHER VERBALLY OR IMPLIED INCLUDING WARRANTIES OF MERCHANTABILITY AND FITNESS FOR A PARTICULAR PURPOSE ARE RECOGNIZED.

THE CONTENTS OF THIS MANUAL ARE SUBJECT TO CHANGE WITHOUT NOTICE AND SHOULD NOT BE CONSTRUED AS A COMMITMENT, REPRESENTATION, WARRANTY OR GUARANTEE OF ANY METHOD, PRODUCT OR DEVICE BY HYDROHOIST INTERNATIONAL, INC.

REPRODUCTION OR TRANSLATION OF ANY PART OF THIS MANUAL, WITHOUT THE WRITTEN PERMISSION OF HYDROHOIST INTERNATIONAL, INC. IS PROHIBITED.

ANY INQUIRIES CONCERNING HYDROHOIST INTERNATIONAL INC.'S PUBLISHED WARRANTY OR THIS MANUAL AND ITS CONTENTS SHOULD BE REFERRED TO:

CUSTOMER SERVICE  
HYDROHOIST INTERNATIONAL, INC.  
915 WEST BLUE STARR DRIVE  
CLAREMORE, OK USA 74017  
PHONE 918-341-6811  
OFFICE HOURS M-F 8AM TO 5PM CT

## **HydroHoist International, Inc. Safety Notice**

TO ENSURE CONSUMER SAFETY, HYDROHOIST INTERNATIONAL, INC. HAS INSTALLED IN THE CONTROL UNIT'S ELECTRICAL SYSTEM AN AC GROUND FAULT CIRCUIT INTERRUPTER (GFCI) DEVICE WHICH IS TO BE USED IN SERIES WITH THE USER'S PRIMARY AC POWER SOURCE. THE GFCI IS AN INTEGRAL PART OF THE HYDROHOIST BOAT LIFT AND IS DESIGNED TO OFFER A LIMITED MEASURE OF PROTECTION TO THE USER AGAINST HAZARDOUS ELECTRICAL CONDITIONS OR SHOCKS SHOULD THEY OCCUR.

THE USER SHOULD BE AWARE OF THE FOLLOWING WARNING:

### **WARNING!**

**IF USER DISABLES THE CONTROL UNIT'S GROUND FAULT CIRCUIT INTERRUPTER (GFCI) DEVICE, HE IS IN DIRECT CONFLICT WITH THE RECOMMENDATIONS OF THE UNITED STATES GOVERNMENT CONSUMER PRODUCTS SAFETY COMMISSION. DISABLING THE GFCI COULD RESULT IN SEVERE ELECTRICAL SHOCK OR DEATH.**

**BEFORE CONNECTING AC POWER TO THE CONTROL UNIT, BE CERTAIN THAT THE PRIMARY AC POWER SUPPLY MEETS ALL APPLICABLE ELECTRICAL CODES.**

ANY INQUIRIES CONCERNING THE GROUND FAULT CIRCUIT INTERRUPTER (GFCI) DEVICE SHOULD BE REFERRED TO:

CUSTOMER SERVICE  
HYDROHOIST INTERNATIONAL, INC.  
915 WEST BLUE STARR DRIVE  
CLAREMORE, OK USA 74017  
PHONE 918-341-6811  
OFFICE HOURS M-F 8AM TO 5PM CT

# CONTENTS

**Getting Started - *Section 1***

**Site Preparation - *Section 2***

**Assembly - *Section 3***

**Installation - *Section 4***

**Final Adjustments - *Section 5***

**Trouble Shooting - *Section 6***

**Parts List - *Section 7***

**EZ Dock Supplement - *Section 8***

# Getting Started

## Assembly Platform

Assembly should be done on a flat, level surface.

A flat-bed trailer is preferred, but a boat trailer with planks across the frame will work, provided that the assembly surface is flat and level

## Tools

A list of tools needed for hoist assembly is given below. In addition to these, tools for boat dock preparation, dock bumper removal, etc. may also be required.

- ◆ 1/2" Drive Ratchet (minimum 9 inch handle length for leverage)
- ◆ Electric Drill
- ◆ 3/4" Deep Well Socket
- ◆ 9/16" Deep Well Socket
- ◆ (2) 15/16" Open-end or Combination Wrenches
- ◆ 3/4" Open-end or Combination Wrenches
- ◆ 9/16 Open-ended or Combination Wrenchs
- ◆ (2) Come-A-Longs
- ◆ 5/16" Nut Runner or medium blade Slotted Screwdriver
- ◆ Medium Phillips Screwdriver
- ◆ Drift Pin or other hole aligning tool
- ◆ Large Hammer (3 or 4 lb. shop hammer is best)
- ◆ Knife or tool for cutting 1" rubber hose
- ◆ Measuring Tape
- ◆ 3/4" Ratcheting Open-end Wrench

## Symbols & Conventions

All references to the LEFT or RIGHT are considered to be facing forward, as if driving a boat into the slip. Left is Port side, Right is Starboard side.

Parts are occasionally described as LEFT or RIGHT to identify their opposing construction, not location on the hoist.

All numbers in brackets [ ] after part names refer to the item numbers on the assembly illustrations within the manual.

# Site Preparation

<b>Verify</b>	The Boat Stall or Mooring Location. <ul style="list-style-type: none"><li>◆ If the hoist is being installed in a commercial marina or multi-slip boat dock, confirm the correct mooring location for hoist and boat.</li></ul>
	The boat specifications. <ul style="list-style-type: none"><li>◆ Make _____</li><li>◆ Model _____</li><li>◆ Length _____</li><li>◆ Beam _____</li><li>◆ Dry Weight of boat _____ lbs.</li><li>◆ Fuel: _____ gal. @ 6.6 lbs./gal. = _____ lbs.</li><li>◆ Water: _____ gal. @ 7.5 lbs./gal. = _____ lbs.</li><li>◆ Gear estimated @ 8% of boat's dry weight _____ lbs.</li><li>◆ Other equipment or weight _____ lbs.</li><li>◆ TOTAL LIFTING WEIGHT _____ LBS.</li></ul>

<b>Inspect</b>	The boat slip, dock or seawall to which the hoist will be installed.
	◆ The structure should be of good, sturdy construction capable of maintaining a secure mooring for the hoist.
	◆ The Dock Brackets, which will be mounted on the dock to provide hoist mooring, have a minimum gripping distance of 4 inches and a maximum gripping distance of 19 inches. Confirm that there is sufficient dock structure for the Dock Brackets.
	◆ The UL2 Shallow Water Lift requires a minimum water depth of <b>21"</b> + <b>hull draft</b> . Confirm that there is sufficient water depth at all times of the year.
	◆ Check for underwater obstructions, such as structural braces, cables, rocks, or sunken objects which will interfere with the hoist's operation.
	◆ Check for overhead obstructions and confirm that sufficient clearance exists for the lifting of the boat.
	◆ Confirm that electrical supply is available and sufficient for hoist operation. The control unit requires 115V and 13 amps.
	◆ Confirm that sufficient dock space is available for mooring the hoist and boat.
	◆ <b>CONFIRM THE BOAT HULL CONFIGURATION - Boats with a stepped hull design, or with through-the-hull apparatus, may require special positioning or alteration to the Hull Support Pads. Contact HydroHoist Engineering Department if proper hull support is in question.</b>

---

# Assembly Instructions

**Description** The assembly instructions presented within this section represent the steps for assembling the UltraLift2 6000 Shallow Water HydroHoist Boat Lift. It is recommended that before assembling the components, you read and understand each procedural step to become familiar with how all parts are assembled.

**Tightening of Fasteners** In the assembly procedures, DO NOT TIGHTEN fasteners until directed to do so. Insert bolts with appropriate washers, lock washers and nuts, but, unless otherwise instructed, leave the fasteners loose to allow movement of the parts for adjustment during assembly. Tighten all bolts at finish of assembly - proper torque specifications for bolts are listed below:

BOLT SIZE	FOOT POUNDS OF TORQUE
1/4-20	5 FT. LBS.
5/16-18	11 FT. LBS.
3/8-16	18 FT. LBS.
7/16-14	28 FT. LBS.
1/2-13	39 FT. LBS.
9/16-12	51 FT. LBS.
5/8-11	83 FT. LBS.

---

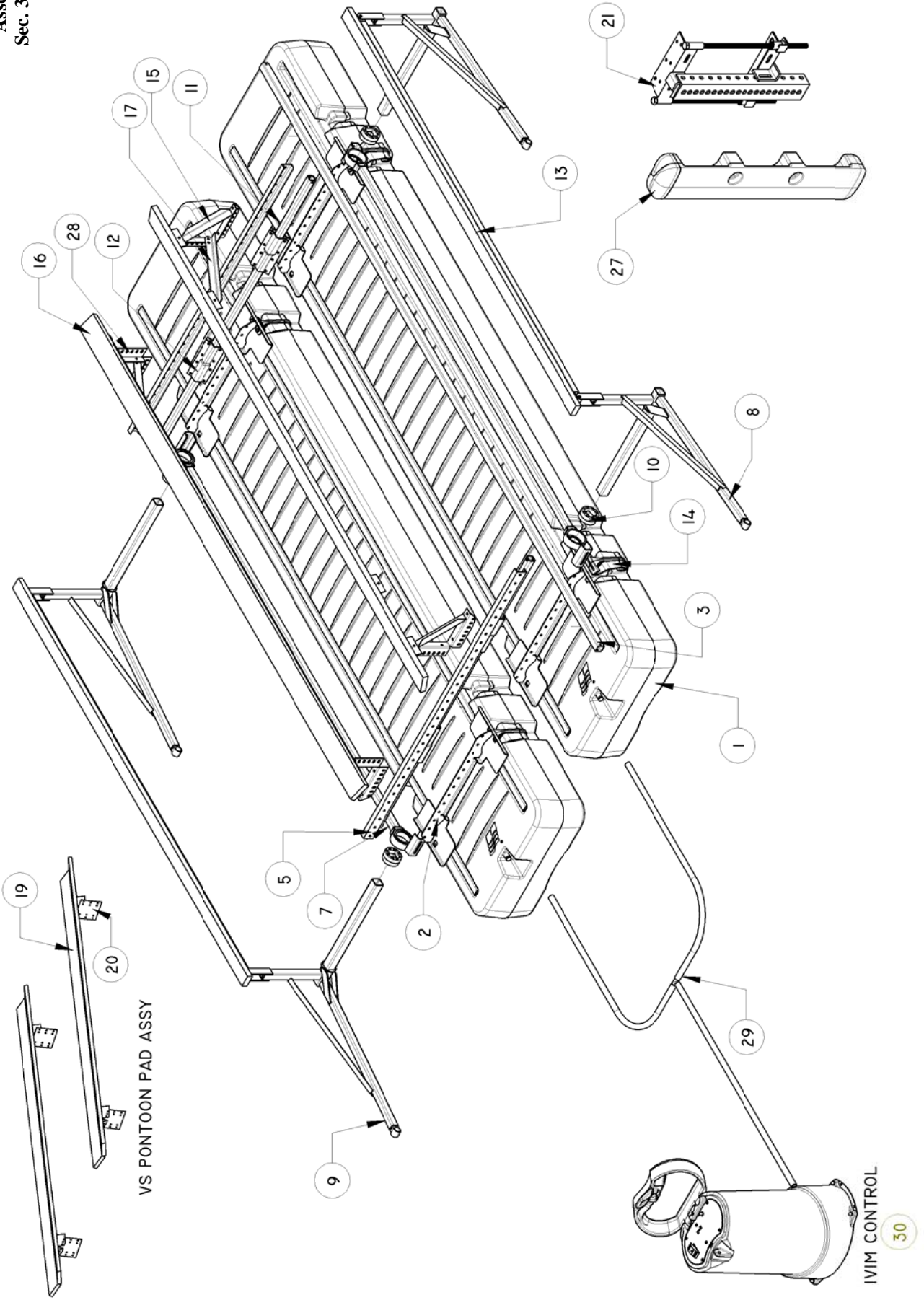

**Tank Bracket Assembly**

*Fig. B*

Step	Procedure
1.1 <i>Fig B</i>	Place the tube brackets [3] in the longitudinal channels which span the top of the tanks.

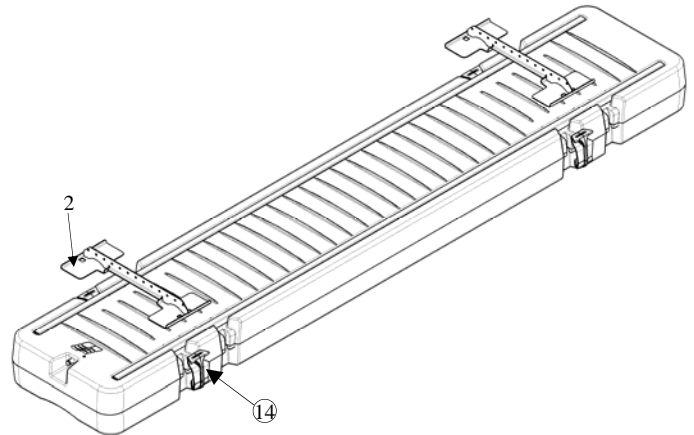
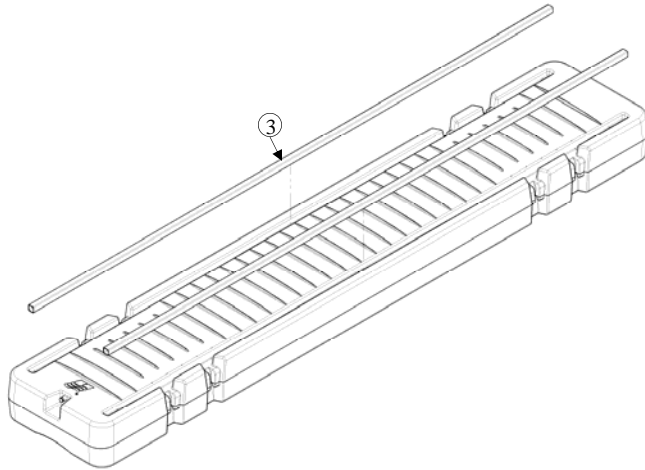

Step	Procedure
1.2 <i>Fig C</i>	Snap the UL2 side brackets [14] into place, followed by placing the Tank bracket [2] on top of the side bracket and attaching with fasteners. Leave fasteners loose until the side stiffeners[7] are installed. Fasteners per cast/plastic bracket: (2ea.) 1/2" X 2 1/2" Hex Head bolts, nuts, and custom washers shown in FIG. C

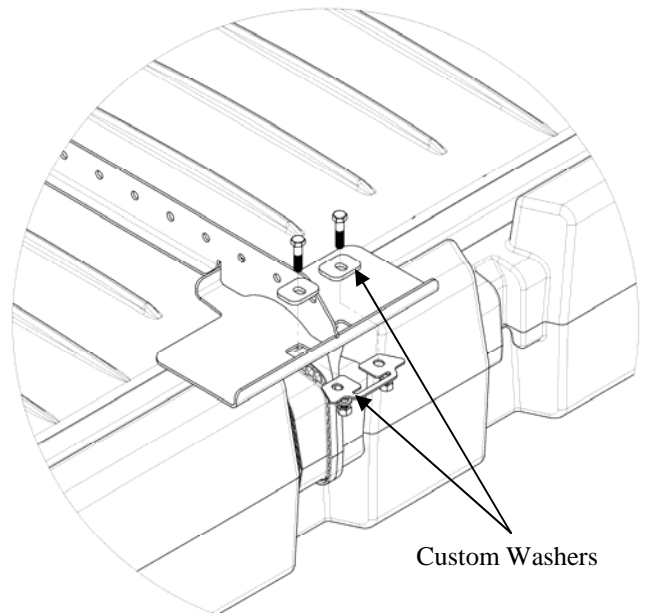
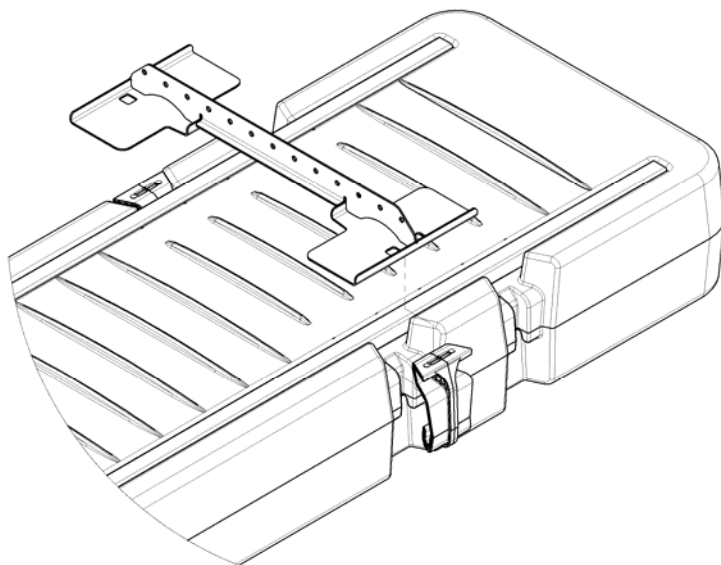

Custom Washers

**End Channel  
 Keel Spanner  
 Assembly**  
 Fig. F

Step	Procedure
2.1	Attach End Channels [5] to Tank Brackets [2] with the End Channel Flanges facing to the center of lift as shown in Fig. E. ( If using Keel Spanners, see step 2.2 for channel or orientation.) Fasteners per Tank Bracket: (2 ea.) 1/2 x 1-1/2 bolt, nut & lockwasher. <b>Note:</b> In a 10' slip tanks need to be further outward, leaving no channel holes open on each side.
2.2	Install Keel Spanners [6] (see section 7 to determine if used) to Tank Brackets [2] with the Keel Spanner Channel Flanges facing to center of the lift as shown in Figs. F&G. In order to face the Keel Spanner Flanges to the center of the lift the end channel will have to be oriented as shown in Figs. F&G. Overall width of the Channel assembly should be 24 inches (+-1 inch) less than the width of the boat slip. Fasteners per Keel Spanner: (1 ea.) 1/2 x 1-1/2 bolt, nut & lockwasher with existing Tank Bracket to End Channel bolts.

Fig. E

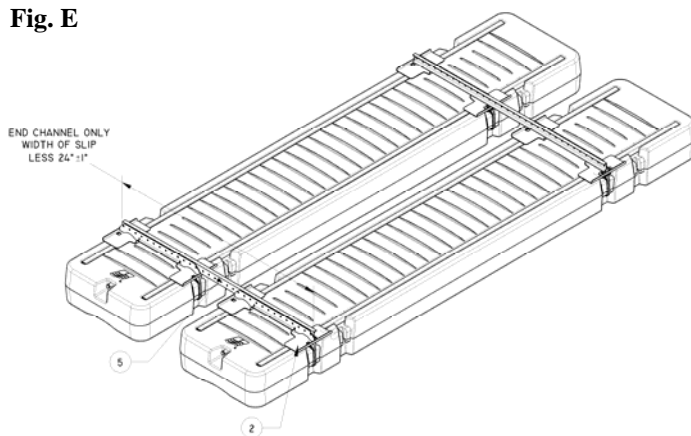
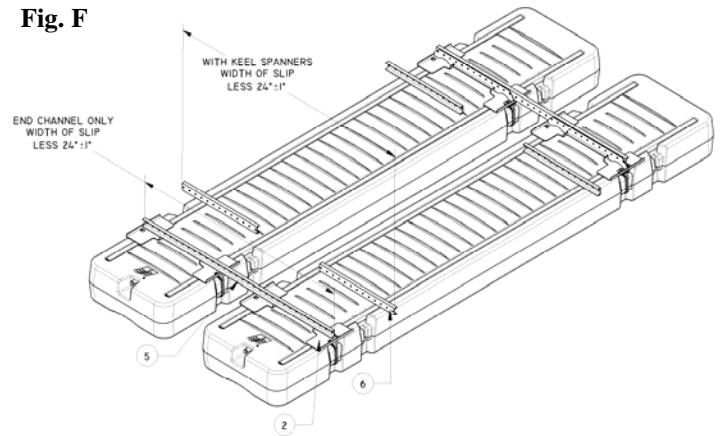

Fig. F



**Side Stiffener**  
 Fig. G

Step	Procedure
3.1	Install Side Stiffeners [7] (with the bearing cage/ring up) to each side of the lift between the Front & Rear End Channels [5] or Keel Spanners [6] if used. Measure the distance from outside edge to outside edge of Side Stiffeners at the front and rear to make sure both are the same width and 25" (+-1 inch) narrower than the slip width. Fasteners per Side Stiffener: (4ea.) 1/2" x 2" bolt, nut, flatwasher & lockwasher. <b>NOTE:</b> • Use flatwashers over slotted holes.

Fig. G

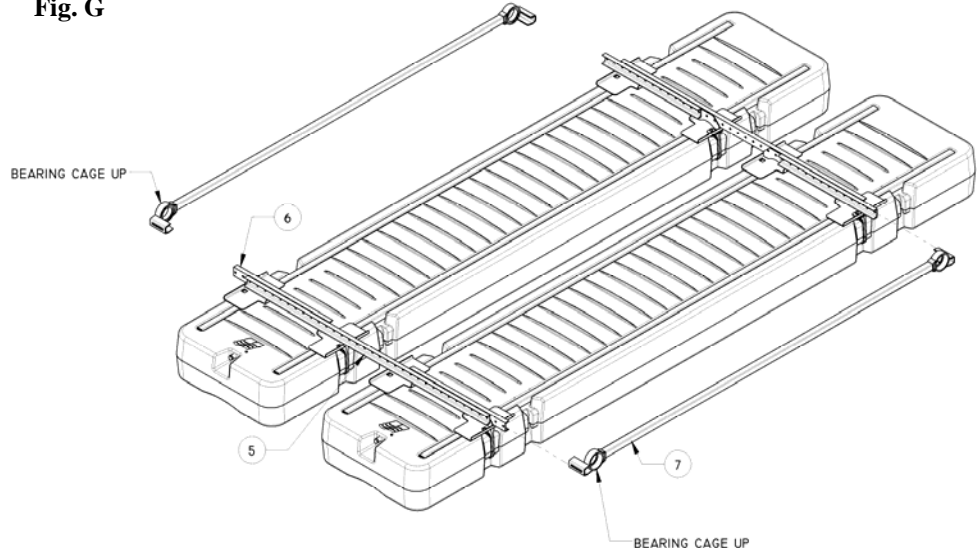

**Stabilizer Arm  
Assembly**  
*Fig. 1*

Step	Procedure
4.1	Install Square Hole Bushing [10] over Torsion Leg of Stabilizer Arm [8-9]. Slide Bushing fully against "clover washer" of Stabilizer Arm.

**Fig. 1**

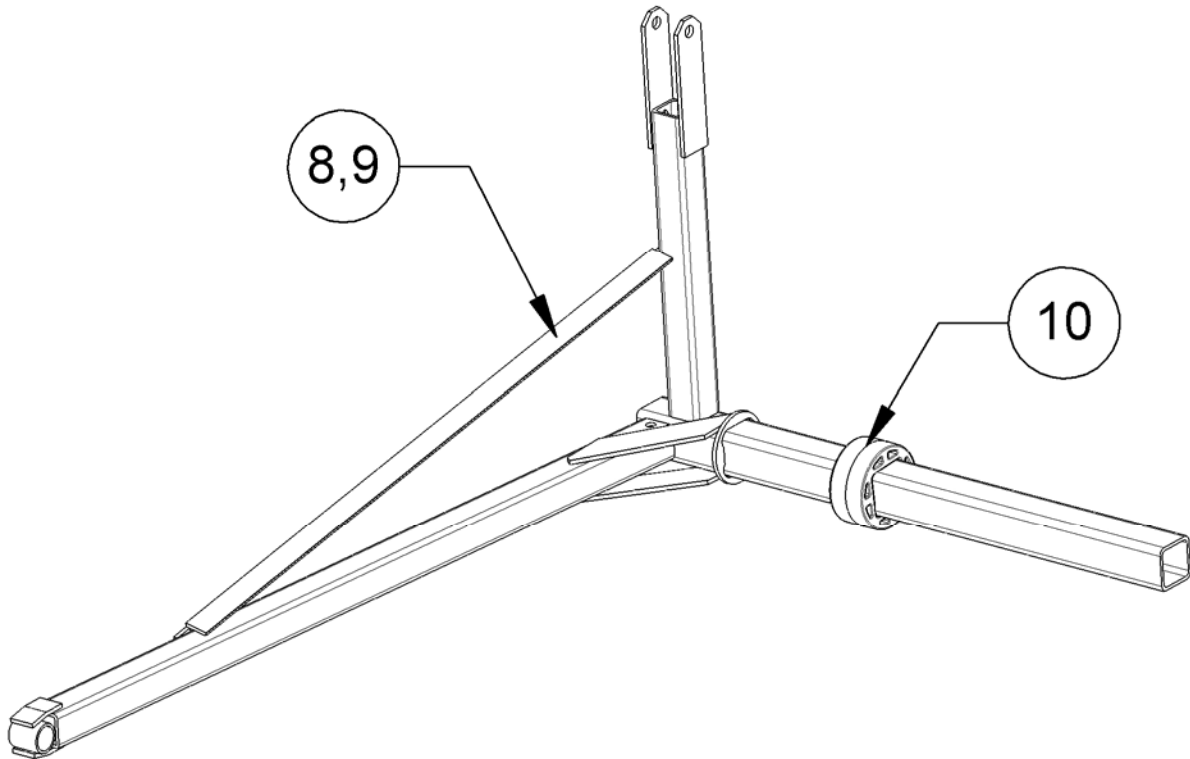

**Stabilizer Arm  
Assembly**  
*Figs. J-1 thru J-4*

Step	Procedure
5.1	Insert each Stabilizer Arm [8-9] through the Bearing Cage (Ring) of the Side Stiffener [7]. <i>For part numbering and reference, the Stabilizer Arms [8-9] are identified as Right and Left. The Right Arm [9] is identified with a welded dot placed on the inside face of the corner brace. The Left Arm [8] has no welded dot. The Arms are universal and either right or left can be used on either side of the lift - see note below.</i>

**NOTE**

Stabilizer Arms [8-9] may be assembled in FOUR POSITIONS:

**Fig. J-1** Arms FORWARD, Pitmans BOATSIDE - *Most common installation.*

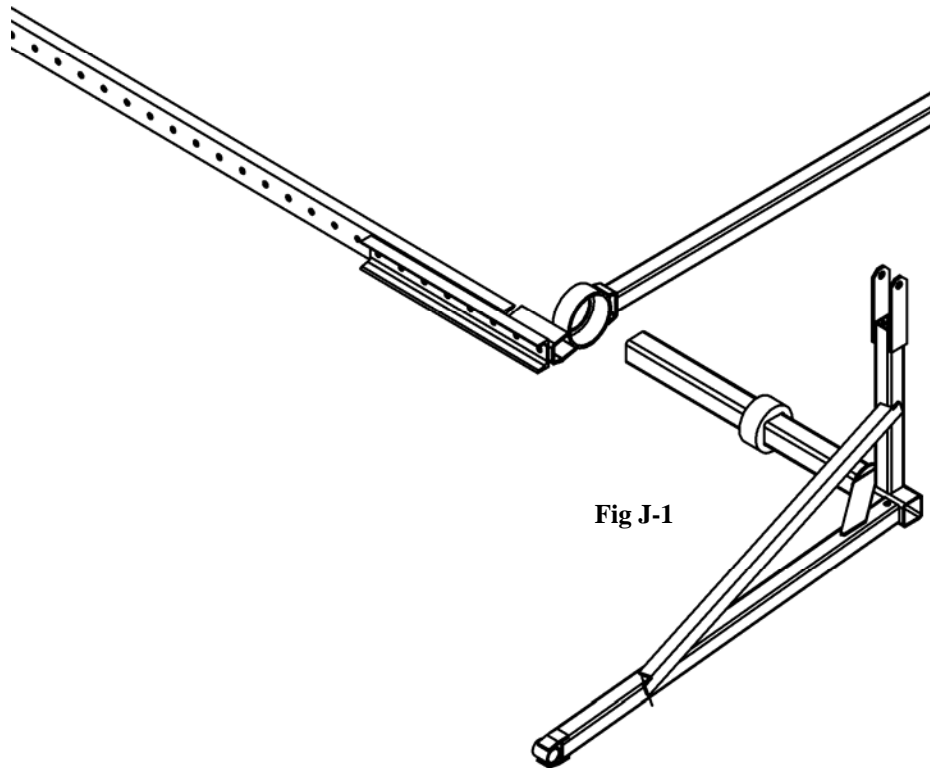

**Torsion Bars**  
 Fig. A.

Step	Procedure
6.1	Slide each Torsion Bar [11] inside the Torsion Leg of each Stabilizer Arm [8-9] at the front and rear of the hoist, making sure that it is an equal distance inside each Leg. <i>Tip: Mark the Center of the Torsion Bar (Example: 5' on a 10' Bar), mark the Center of the End Channel, then align the Center marks.</i>
6.2	Temporarily chain the Rear* Stabilizer Arms to a slightly raised position: <ol style="list-style-type: none"> <li>1. Raise one Rear Stabilizer Arm to horizontal.</li> <li>2. Using a Chain from Parts Bag, form a loop around the Side Stiffener [7] and the end of the Stabilizer Arm.</li> <li>3. Fasten the loop by bolting the chain links together with a 3/8" x 2-1/4" bolt, <u>double-nuts and double flat washers</u>.</li> <li>4. Repeat on opposite side Rear Arm, making the two Arms parallel to each other.</li> </ol> <i>This is a temporary attachment, used to assist in further assembly and to transport the lift to the boat dock - Although it is temporary, it must be secure enough to prevent the arms from lowering accidentally.</i>  *Chain Front Stabilizer Arms if installed AFTWARD.

**Pitman Assembly**  
 Fig. K.

Step	Procedure
7.1	<ul style="list-style-type: none"> <li>• <i>Follow this step, one end at a time for each Pitman.</i></li> <li>• <i>The Carpeted Board OVERHANGS steel on one side of the Pitman—THIS OVERHANG SHOULD BE INSTALLED INBOARD (CENTER) OF THE LIFT.</i></li> </ul> Insert Poly Bushing and Stainless Steel Bushing into Bushing Sleeve at end of Pitman [13]. Place Pitman [13], with Bushing inserted, into clevis of Stabilizer Arms [8-9] rotate Stabilizer Arm into position if necessary to mate parts. Connect assembly with bolt inserted from inboard side. Fasteners (Grade 8) per Pitman: (2) 5/8" x 3-1/2" bolt, lock nut & lock washer. <b>Tighten NOW to 83 ft.-lbs. of torque.</b>

**Fig. K**

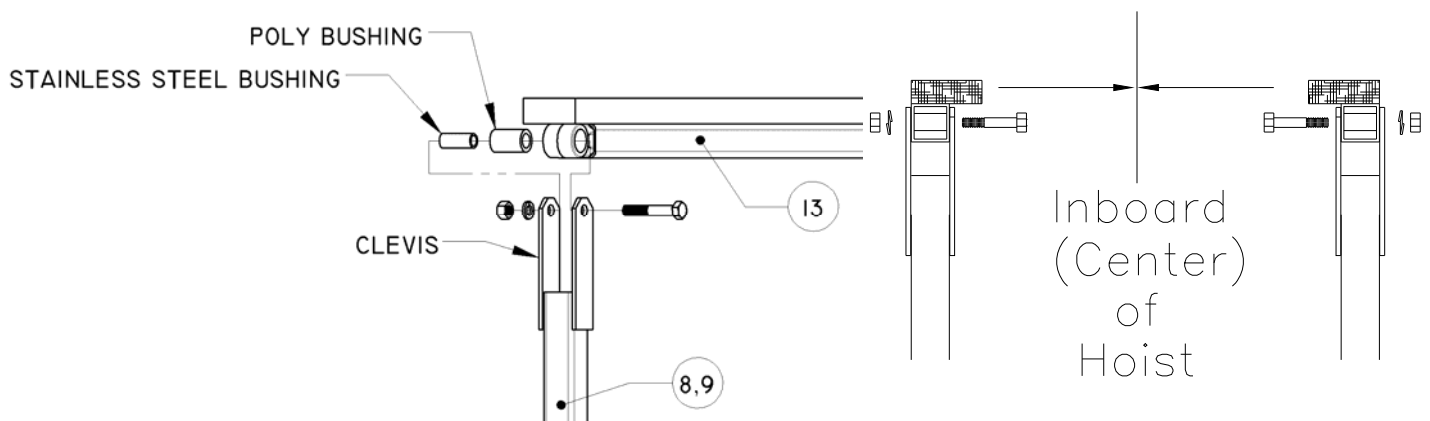

**Note...** The parts installed in the **next steps** may have to be moved to better fit the bottom of the boat after it has been lifted. Accurate measurements of the boat's hull before assembly and careful attention to these steps may prevent repositioning the parts over the water.

**Positioning...** If the boat hull is unable to be measured prior to hoist assembly, space the **rear** Hull Support Columns [14-15] 36" to 42" apart, and the **front** Column 3" narrower than the rear.

**Hull Support  
 Assembly**  
 Figs. L

Step	Procedure
8.1	Attach two Hull Support Columns [15,28] to front End Channel [5] and two Hull Support Columns to the rear End Channel. Attach the columns with the flat side of the angles opposite each other, and the brace angle of the column <u>outboard</u> . Fasteners per Column: (2ea) 1/2" x 1-1/2" bolt, nut & lockwasher.
8.2	Attach Hull Support Pads [16] to the tops of the front and rear Hull Support Columns [15-28]. The pad's long angle iron frame member should be <i>inboard</i> so that its weight keeps the pad tilted inboard, following the boat hull. Fasteners per Pad: (2ea) 1/2" x 5" bolt, nut & lockwasher.
8.3	Install the Hull Support Pad Braces [17] between the Hull Support Pads [16] and the Hull Support Columns [15,28]. <i>The flat side of the braces face inboard</i> . Fasteners per Brace: (1ea) 1/2" x 1-1/2" bolt, nut & lockwasher at Column; (1ea) 1/2" x 5" bolt, nut & lockwasher at Hull Support Pad.
8.4	<b>Tighten</b> the 5" Hull Support Pad bolts only enough to flatten the lockwashers. <b>Do not tighten any other bolts at this time.</b>

**Fig. L**

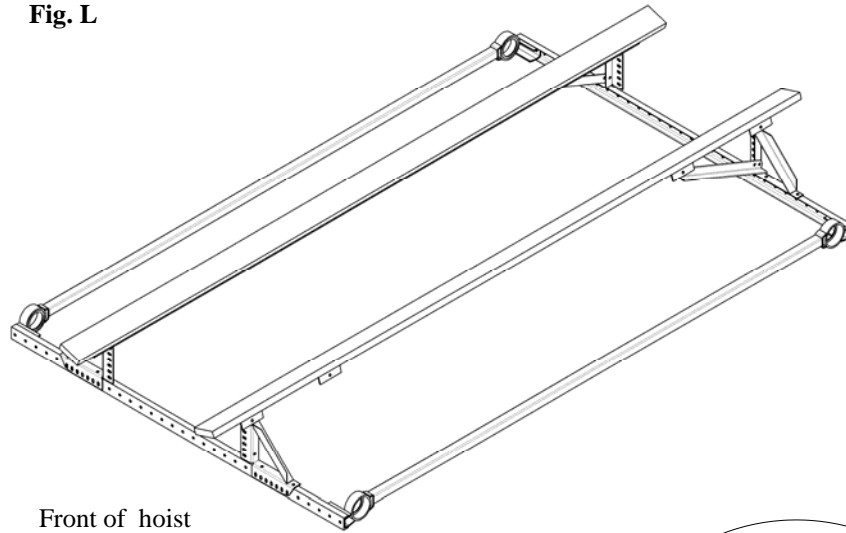

Front of hoist

Optional VS Pontoon  
 Pad Assembly

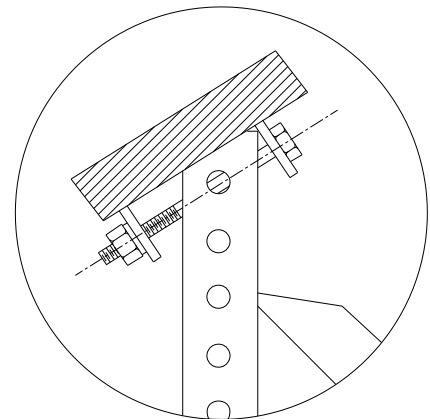
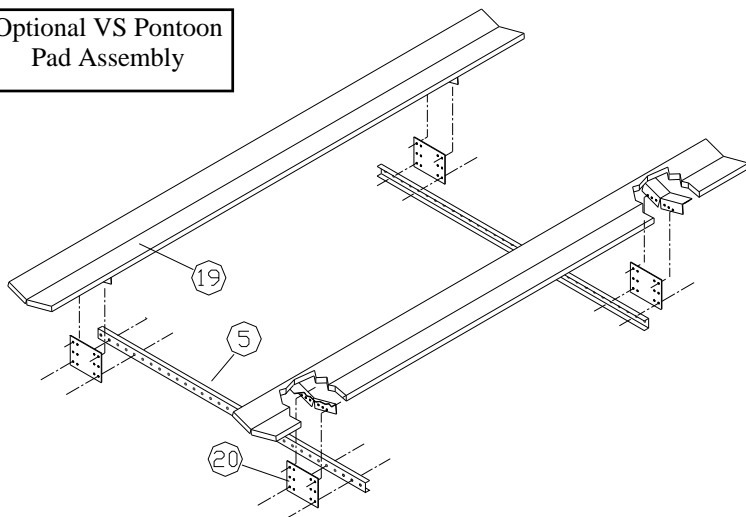

**Leveling the Hoist**

Step	Procedure
9.1	<b>THIS STEP IS VERY IMPORTANT</b> Stand at the rear of the hoist and sight across the <b>rear</b> End Channel to the <b>front</b> End Channel to make sure the <b>front and rear are parallel</b> and that there is no twist or warp in the hoist. If one corner appears to be low, place a block under that corner to level the lift. Repeat sighting, and continue adjusting until lift is level.
9.2	<b>With the lift level, tighten all remaining 1/2" bolts to 40 ft-lbs of torque, tighten all 5/8" bolts to 83 ft-lbs of torque.</b>

**Tightening All Fasteners**

**Torsion Bar Clamps**  
 Fig. M

Step	Procedure
10.1	Push all four Stabilizer Arms [8-9] fully against the Side Stiffener [7] so that there is <b>no lateral clearance</b> between Side Stiffener, Square Hole Bushing, and Stabilizer Arm. <b>IMPORTANT, all four stabilizer arms must be parallel with each other to insure level operation.</b>
10.2	Assemble two halves of Torque Manager [12] at each end of each Stabilizer Arm Torsion Tube placing 1/2 of the Torque Manager over the Stabilizer Arm Torsion Tube and 1/2 over the Torsion Bar [11]. - see Fig. M. Fasteners per Torsion Bar (8 ea) 1/2" x 2" bolt, nut & lockwasher.
10.3	With the Stabilizer Arms parallel to each other, <b>TIGHTEN THE TORQUE MANAGER BOLTS AS TIGHT AS POSSIBLE (APPROX. 40 FT.-LBS. TORQUE)</b>

Stabilizer Arm Torsion Tube

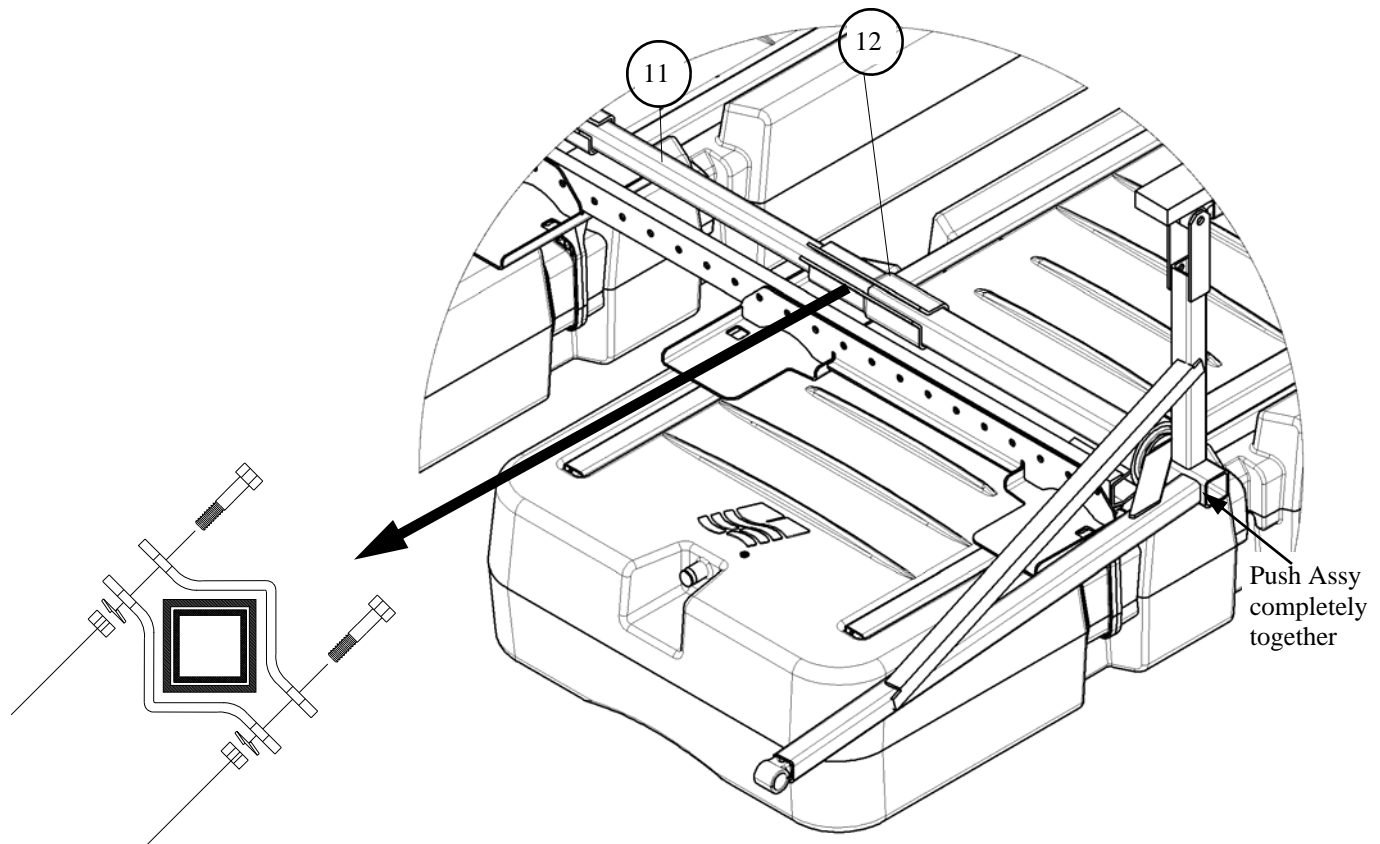

**Hose Assembly**  
*Fig. N*

Step	Procedure
11.1	Attach Hoses to Tanks and to Control Unit [30] using Hose Clamps.

**Fig. N**

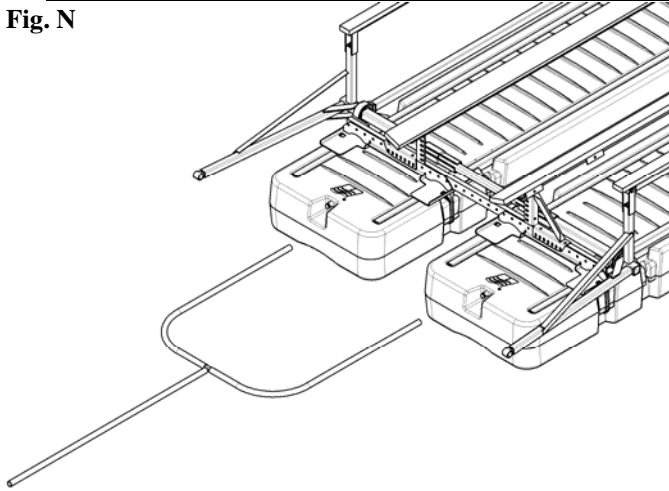

**Final Steps**

Step	Procedure
12.1	Using a Ratchet Puller ("Come-A-Long") connected near the ends of the front Stabilizer Arms [ 8-9], pull the front Stabilizer Arms inboard approximately three inches total. <i>Note: Attach the hooks of the Come-A-Long near the end of the Arm, but NOT through the mounting hole at the Arm's end. In assembling the hoist, the Arms are slightly WIDER than the Dock Bracket attachment points. The purpose of pulling the Arms inboard, is to allow the Arm ends to position between the Dock Bracket.</i>
12.2	Repeat Step 12.1 above with the rear Stabilizer Arms. <i>Note: The cable of the Come-A-Long should extend <u>under</u> the Side Stiffener.</i>
12.3	Secure the Control Unit [30] to the Hull Support Pads and make sure all Valves are closed in the Dry-Dock position.
12.4	Attach a towing line to the rear End Channel. Tank Plugs are recommended for all tows. (Tank Plug Part No. 2905406).
12.5	Slowly tow the hoist to its mooring location.

## Selecting Position for Boat & Hoist (BOW FIRST LOADING) Fig. O

Step	Procedure
1.1	<b>BOW FIRST LOADING ONLY</b> Pull the <b>boat</b> into the boat stall so that the bow can be easily reached from the front of the slip, and allow at least 12 inches of space at the dock level between the dock and the boat in the event the boat may need to be later moved in final positioning.
1.2	With the boat in the desired location, place a mark on the dock where the boat's transom is positioned. <b>Note: Do not include extensions to the hull such as swim platforms; the transom mark should reflect the location of the the end of the bottom of the hull.</b>
1.3	Remove the boat and pull the <b>hoist</b> into the berth.
1.4	Position the hoist along side the dock and align the <b>rear end</b> of the Hull Support Pads with the <b>transom mark</b> on the dock.
1.5	With the hoist held stationary at this position, place <b>marks</b> on the dock at the location of the <b>Stabilizer Arm attachment points</b> .

Fig. O

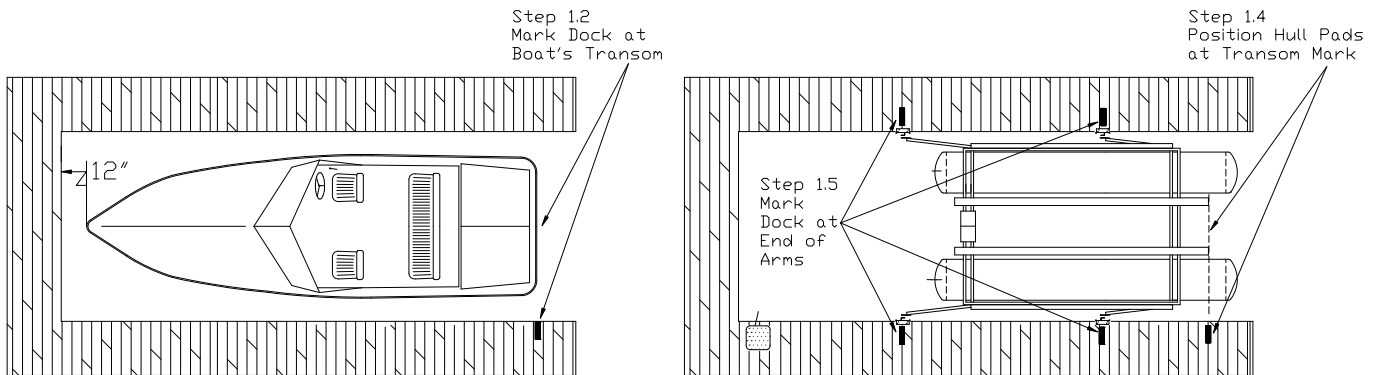

## Dock Bracket Attachment Fig. P

Step	Procedure
2.1	Attach Dock Brackets with the holes of the Vertical Angles [25] aligned with the marks on the dock. Note: Grip Tabs [26] must be installed to reduce inboard movement of the Lower Dock Bracket Angle [23]. If Grip Tabs are not applicable, it will be necessary to (later) <b>through-bolt</b> the Dock Bracket to the dock structure to eliminate inboard movement. Fasteners: 2 Grip Tabs per Dock Bracket - 2 ea 1/2" x 1" Carriage Bolt & nut. Tighten to 40 ft. lbs. of torque.
2.2	Tighten the 20" Dock Bracket Bolts [24] just enough that the Dock Brackets will stay in position - <i>do not fully tighten at this time, further horizontal adjustment may be needed later.</i>

Fig. P

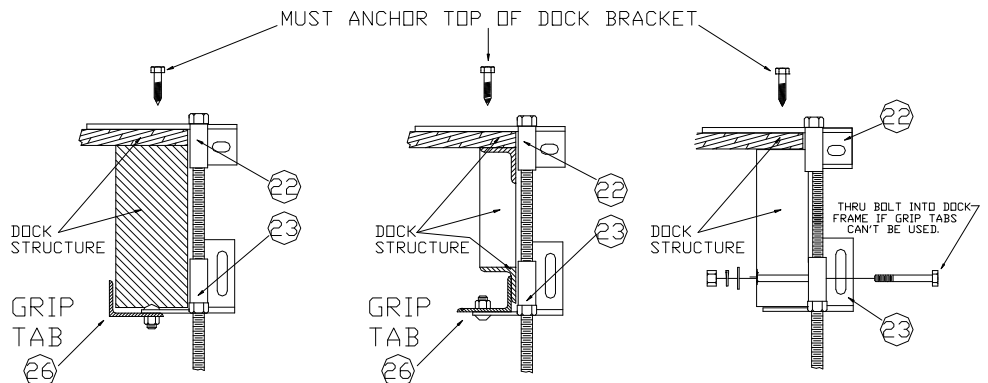
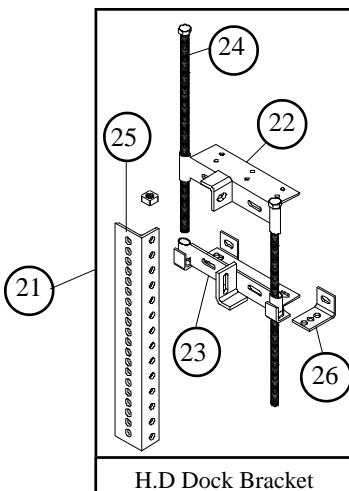

**Lift Attachment**  
*Fig. Q*

Step	Procedure
3.1	Float hoist into position with the arms lined up with the Dock Brackets.
3.2	Loosen <i>front</i> "come-a-long" <u>only enough</u> to allow the <i>front</i> Stabilizer Arms [8-9] to touch the Vertical Angles [25] of the Dock Brackets.
3.3	<b>SELECT PIVOT BOLT HEIGHT:</b> The optimum Pivot Bolt location is any point between the Upper and Lower Dock Bracket Angle. At no time should the Pivot Bolt be located below the Lower Dock Bracket Angle a distance <b>greater</b> than the distance between the Upper and Lower Dock Bracket Angles. <b>See Fig Q</b>
3.4	<b>FRONT ARMS ONLY -</b> Insert Poly & Stainless Steel Pivot Bushings into the Pivot End of <b>one front</b> Stabilizer Arm [8-9]. Attach Stabilizer Arm to Vertical Angle [25] of Dock Bracket - <i>it may be necessary to push down or lift up on the Arm to access the selected pivot location.</i> Fasteners per Arm: (1 ea) Grade 8 - 5/8" x 3-1/2 bolt, flat washer, lock washer, & lock nut. <b>TIGHTEN AS TIGHT AS POSSIBLE (ABOUT 83 FT-LBS).</b>
3.5	<b>MEASURE THE DISTANCE FROM THE PIVOT BOLT TO THE WATER - THIS DISTANCE WILL BE REPEATED FOR THE OTHER THREE ARMS - ALL PIVOT BOLTS MUST BE AN EQUAL DISTANCE ABOVE THE WATER.</b>
3.6	Repeat Step 3.4 with opposite <i>front</i> Stabilizer Arm [8-9]. ( <b>Do Not</b> loosen or remove come-a-longs at this time). <b>TIGHTEN AS TIGHT AS POSSIBLE (ABOUT 83 FT-LBS).</b>
3.7	<b>REAR ARMS ONLY -</b> Insure hoist is square in the slip by measuring the distance between the right and left Stabilizer Arms [8-9] and the Vertical Angles [25] of their Dock Brackets. If the distances <u>are not equal</u> , correct by moving one of the <b>front</b> Dock Brackets forward or backward until the hoist is square in the slip.
3.8	Loosen <i>rear</i> "come-a-long" <u>only enough</u> to allow the <i>rear</i> Stabilizer Arms [8-9] to touch the Vertical Angles [25] of the Dock Brackets. Attach Arms [8-9] to Vertical Angles [25] as in Step 3.4. <b>TIGHTEN AS TIGHT AS POSSIBLE (ABOUT 83FT-LBS).</b> ( <b>Do Not</b> loosen or remove come-a-longs at this time). <b>NOTE-</b> <i>It may be necessary to stand on the rear of the hoist with the Control Unit Valve open (Launch) until hoist lowers enough to connect the rear Arms at the selected pivot locations....CAUTION -Maintain at least 4" of tank above the water, and be sure to close the Valve when position is achieved.</i>

Fig.Q

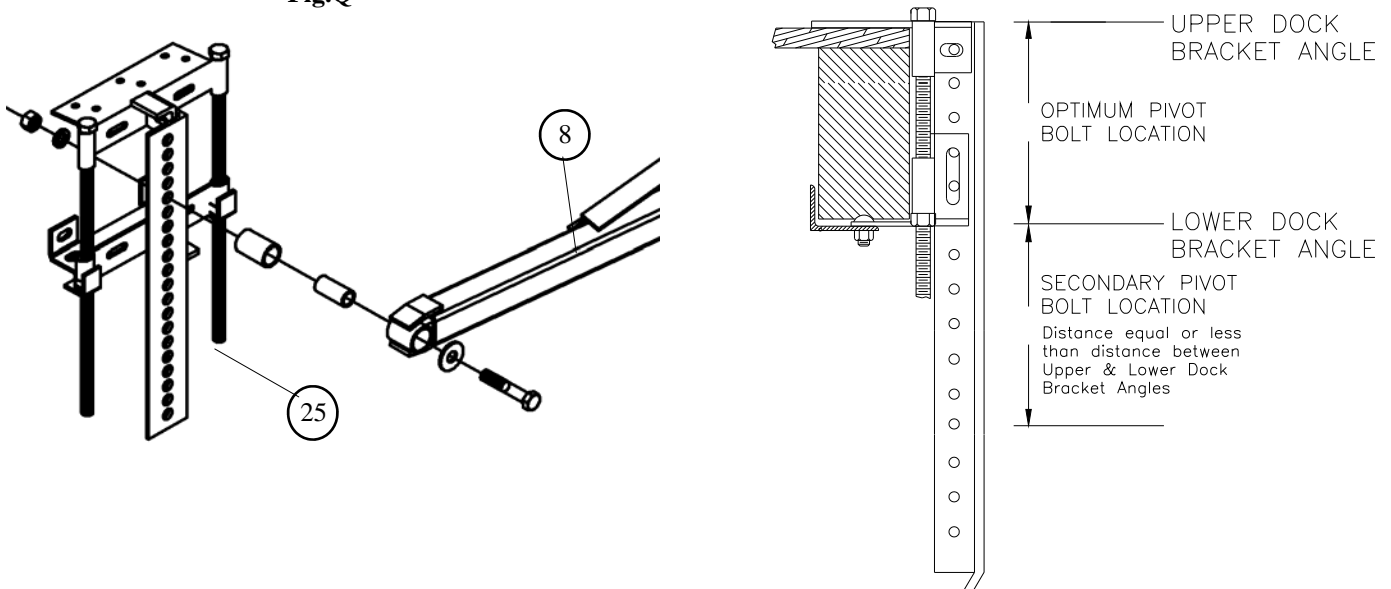

### Anchoring Dock Brackets

Fig. P & Q

Step	Procedure
4.1	Make sure the Dock Brackets are fully against the dock structure, then <b>TIGHTEN</b> the 20" Dock Bracket Bolts [24] to about 35 ft-lbs of torque.
4.2	With the Come-a-longs still attached, <b>ANCHOR</b> the <i>top</i> Dock Bracket Angles [22] to the dock to prevent inboard movement. <b>See Fig. P.</b> Fasteners: Installer's option, depending on dock construction material.
4.3	Remove the Come-a-longs. As the Come-a-longs are released, the Arms must exert additional "out-pressure" against the Dock Brackets. <i>If there is no out-pressure, double check original slip measurements and hoist assembly width. Two inches of out-pressure may be gained by loosening the Torsion Bar Clamps and Side Stiffeners and forcing the Side Stiffeners outboard. If greater than two inches of adjustment is necessary, the hoist must be rebuilt by changing the End Channel and Keel Spanners.</i>
4.4	If Grip Tabs [26] were not used, <b>ANCHOR</b> the <i>bottom</i> Dock Bracket Angles [23] to the dock by thru-bolting the Angles to the dock. <b>See Fig. P.</b> Fasteners: Installer's option, depending on dock construction material.

### Catch Chains

Fig. R

Step	Procedure
5.1	Remove the 3/8" x 2-1/4" bolt, double nuts and double flat washers from the chains previously looped around the Side Stiffeners and Arms. Make a small but loose loop of chain around (each) Side Stiffener [7]. Fasteners per Chain: (1 ea) 3/8" x 2-1/4" bolts, double nuts, and double flat washers.
5.2	Attach other end of Chain to Vertical Angle [25] at a point <b>BELOW</b> the Pivot Bolt. Fasteners per Chain: (1 ea) 3/8" x 2-1/4" bolts, double nuts, and double flat washers. Tighten to 18 ft. lbs. torque. <b>IMPORTANT:</b> <ol style="list-style-type: none"> <li>Chain length must be <b>equal length</b> on each side of hoist - unequal length may cause hoist to lift high and launch low on one side.</li> <li>Length of Chain (attachment point) is determined by: <ul style="list-style-type: none"> <li>The height of the attachment point above the water.</li> <li>The draft of the boat.</li> </ul> </li> <li>The Ideal length allows the hoist to lower just enough to allow the boat to easily pass over hoist when boat is loaded with crew and gear, and in rising and falling waves.</li> <li>The Chains must never be loose when the hoist is in the fully down position - this indicates that the hoist is too low and the Stabilizer Arms are binding against the Pitmans causing damage to parts.</li> </ol>

Fig. R

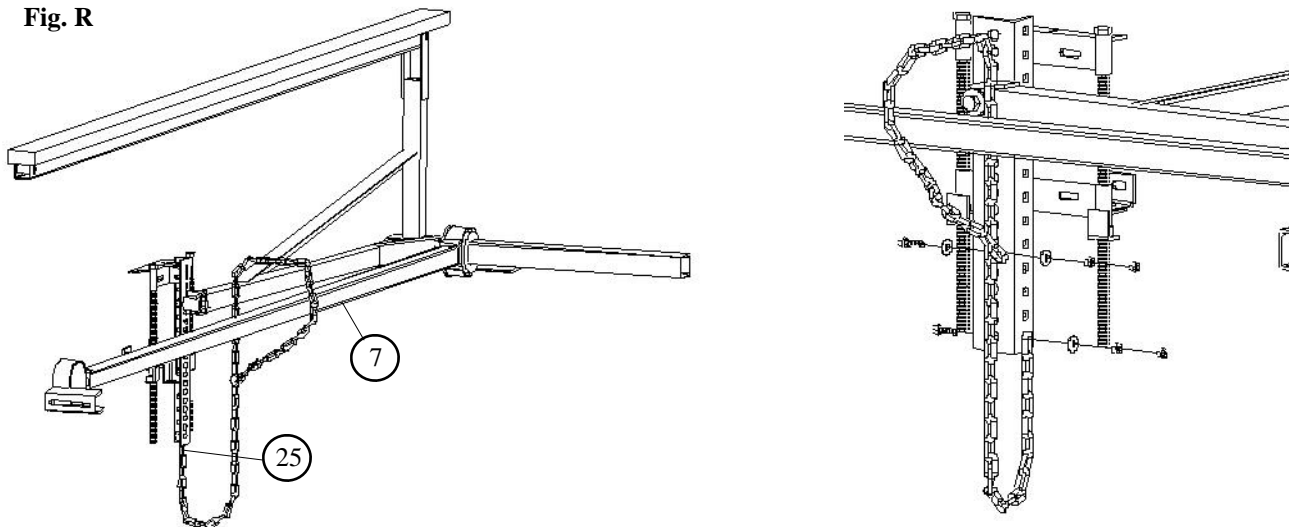

**Adjustments**

Step	Procedure
6.1	CHECK ALL DOCK BRACKET BOLTS FOR TIGHTNESS. CHECK ALL OTHER BOLTS FOR TIGHTNESS.
6.2	Attach the Control Unit to the dock in the desired location and connect the power cord to proper power source. Test the motor switch to ensure operation.
6.3	Remove Tank Plugs if used.
6.4	Lower the hoist according to the OPERATING INSTRUCTIONS (inside Control Unit). With the hoist submerged, check to see if the Catch Chains are tight - if not, shorten the Chains to the point that hoist is suspended by the chains.
6.5	Raise the hoist to the point the frame (front and rear End Channels and Side Stiffeners) are just above the water. The frame should be equal height (within 3 inches) above the water at all four corners - if not, measure from the Pivot Bolts to the waterline. <i>Note: If all Pivot Bolts are correct, and the hoist is still uneven, the hoist was assembled uneven. See Section 6 - Trouble Shooting</i>

**HydroGuards**

*Fig. S*

Step	Procedure
7.1	Attach HydroGuard[27] to the Dock Bracket Vertical Angle [25] in the 3rd hole above the arm bolt, or the 7th hole below the arm bolt, depending on arm location along vertical angle[25]. Fasteners per HydroGuard: (2 ea) 5/8" x 4" bolt, nut and lockwashers. Tighten to 20 ft. lbs.

**Fig. S**

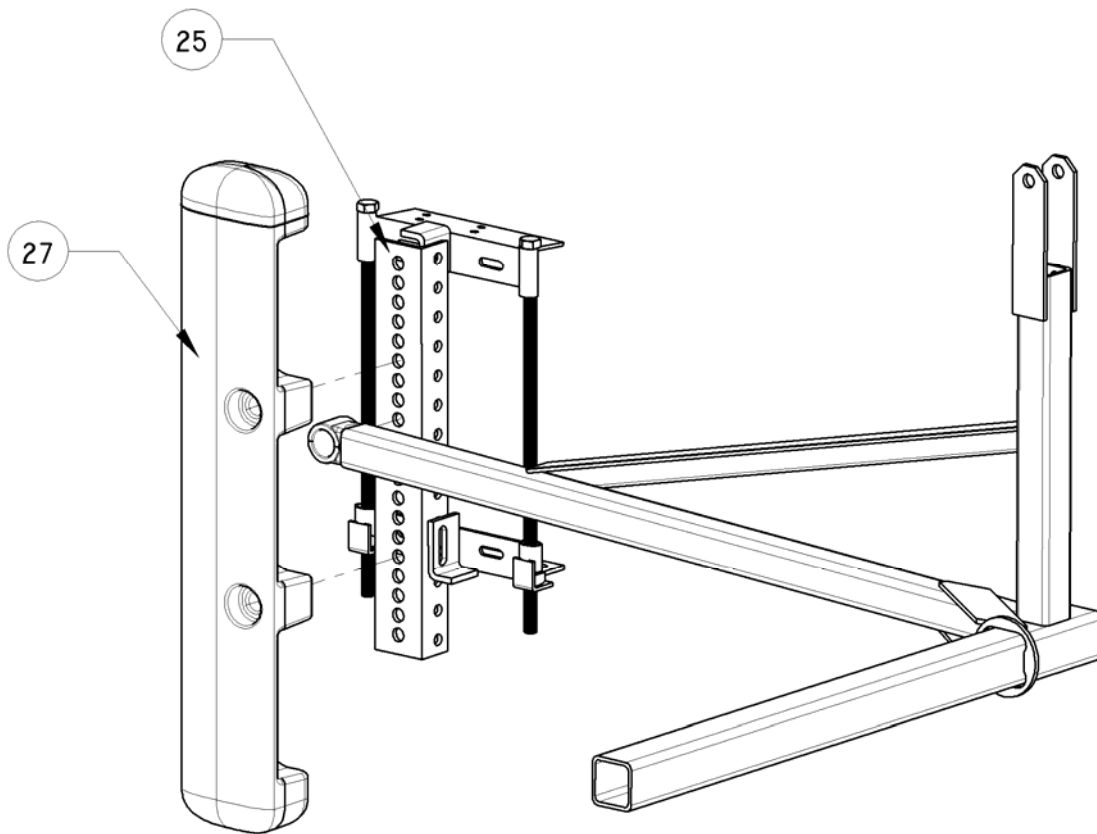

# Final Adjustments

## Lifting the Boat

Step	Procedure
1.1	Pull the boat over the hoist and align the boat's transom with the mark on the dock (Sec. 4 Step 1.2). <i>This will properly position the transom just above the end of the Hull Support Pads as the hoist rises.</i>
1.2	Hold the boat in position at the transom mark and center it side to side over the hoist.
1.3	<b>Continue holding the boat in position</b> , rotate the Control Unit Valve(s) to the Lift/Launch position and turn the Power Switch to the ON position and continue holding boat in position until hoist makes contact with boat. <i>Note: It may be necessary to reset the GFCI switch to activate the Switch.</i>
1.4	Allow hoist to lift boat and observe the lifting operation - <ul style="list-style-type: none"><li>• STOP LIFTING if boat is off center side-to-side or fore-to-aft. Lower hoist and reposition boat.</li><li>• STOP LIFTING if Dock Bracket movement is observed. Lower hoist and secure Dock Brackets.</li><li>• STOP LIFTING if hoist is not rising level. Lower hoist and reposition boat.</li></ul>
1.5	<b>STOP LIFTING</b> as soon as the frame is out of the water, but the hoist is not fully raised. Observe the distance from the waterline to each corner of the hoist - <b>each corner should be an equal distance (within 3 inches) above the waterline.</b> <ul style="list-style-type: none"><li>• If the hoist is out of level in excess of 3 inches front to rear, or the dock fingers appear to be loaded excessively, lower hoist and reposition boat toward the high end of the hoist.</li><li>• If the hoist is out of level in excess of 3 inches side to side the boat may be loaded off center or the Torsion Bar Clamps are not tight.</li></ul>
1.6	Continue lifting the boat until air bubbles appear from all tanks. Turn the Power Switch to OFF and rotate Control Unit Valve(s) to the Dry Dock position. The hoist and boat should now be fully lifted.
1.7	<b>INSPECT HOIST AND BOAT:-</b> <ul style="list-style-type: none"><li>• Check Hull Support Pad locations for proper fit to boat hull - the boat should be centered side to side with the Pads contacting the hull between the chines and the rear of the Pads should extend to include the engine compartment. <b>Note: it is acceptable for the Hull Pads to cross the chines at the bow, but not acceptable from mid-ship to stern.</b></li><li>• Check Hull Pad Assembly for proper height and fit to hull.</li><li>• Check Dock Brackets for secure hold.</li><li>• Check all components for correct operation.</li></ul>

**Guide Ropes**

Step	Procedure
2.1	<b>With hoist, Hull Support Pads and boat correct</b> , lower hoist until boat is almost free floating and place Control Unit Valve(s) in Dry Dock position.
2.2	Tie a small loop (about 6 inches in diameter) in one end of each Guide Rope and place the loops over the REAR cleats of the boat.
2.3	Tie the Ropes (tight, no slack) to a roof support post forward of the front Dock Brackets and 6 to 7 feet <i>above</i> the deck of the dock. NOTE: If no overhead structure is available, the forward end of the Guide Ropes may be tied to (only) the FRONT End Channel of the hoist. <b>DO NOT attach Ropes to any other structure or component of the hoist.</b>

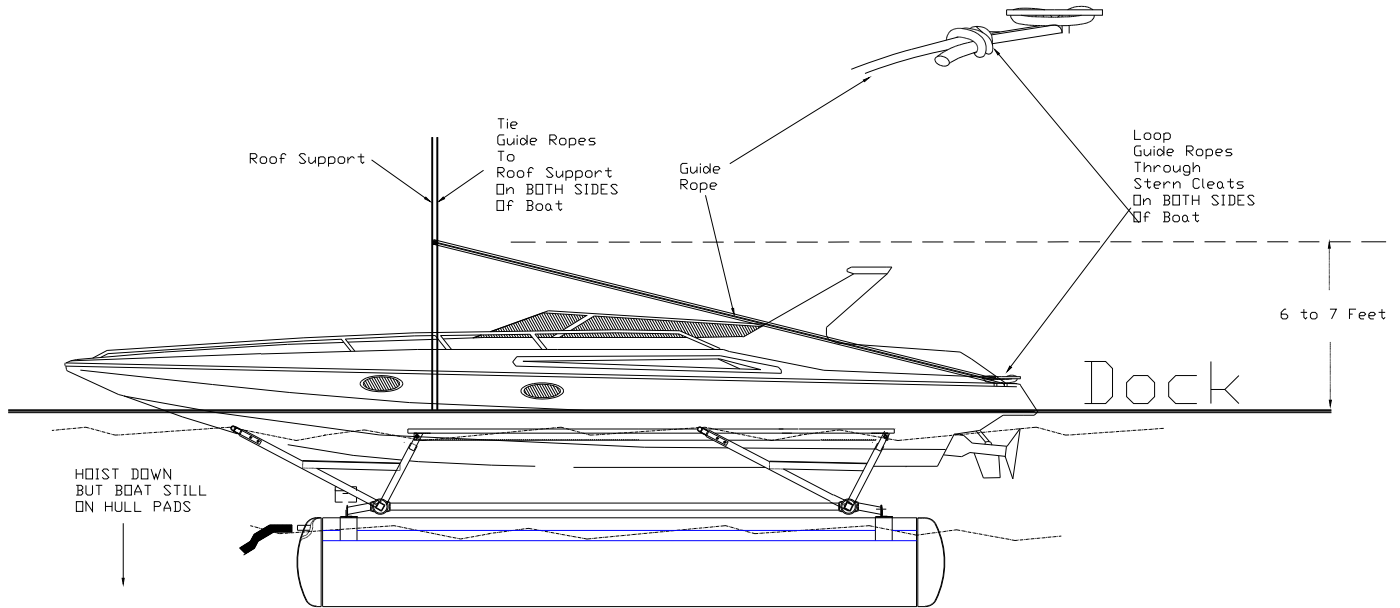

**Final Inspection**

Step	Procedure
3.1	Operate the hoist again - <b>launch then lift</b> - checking for proper positioning of the boat and Hull Support Pads, and for proper operation of the lift.

**Wrapping Up**

- ◆ Secure a bow line to the boat and to the boat dock.
- ◆ Confirm that the Operating Instructions are in the Control Unit.
- ◆ Unplug the power cord and stow it in a secure position.
- ◆ Complete the Warranty information and apply the adhesive Serial Number Tag to the Top Plate of the Control Unit.
- ◆ Close and secure the Control Unit Lid.
- ◆ Whenever possible, instruct the boat owner in the proper operating procedures of the hoist.

# Trouble Shooting

<b>CONDITION:</b>	Hoist will not completely lift boat from water or stern remains low.
<b>CAUSE:</b>	A Water or equipment in boat creating additional weight. B Boat weight exceeds lifting capacity of hoist.
<b>CORRECTION:</b>	A Remove water or equipment. B Install correct size hoist to accommodate the boat's true weight.
<b>CONDITION:</b>	Hoist tips to side when lifting or launching.
<b>CAUSE:</b>	A Restricted air flow to one of the lifting tanks. B Hoses not of equal length. C Hoist is not square, frame is twisted. D Catch Chains not of equal length.
<b>CORRECTION:</b>	A Remove kinks or water-lock from hoses. B Correct hose length. C Loosen Tank Bands, Torsion Bar Clamps level hoist. D Adjust length of Catch Chains.
<b>CONDITION:</b>	Hoist leans to one side.
<b>CAUSE:</b>	A Torsion Bar not properly adjusted. B Pivot Bolts not equal height above waterline.
<b>CORRECTION:</b>	A Loosen Torsion Bar Clamps , level hoist. B Correct height of Pivot Bolts.
<b>CONDITION:</b>	Hoist leaks down on one side.
<b>CAUSE:</b>	A Leak in valve, tank, or hose.
<b>CORRECTION:</b>	A Locate leak and repair.

**CONDITION:** Control Unit Blower not working.

**CAUSE:**  
 A GFCI circuit open.  
 B Switch or Blower Motor malfunctioning.  
 C Power service to dock not on.

**CORRECTION:**  
 A Reset GFCI switch.  
 B Replace Switch or Blower Motor.  
 C Turn on service to dock.

**CONDITION:** **Air trapped in tanks.** Front of hoist below water, rear of hoist above water.

**TO MANUALLY EXHAUST AIR FROM TANKS:**

- 1 INSERT PVC TUBE ASSEMBLY INTO TANK AT WATER DISCHARGE HOLE.
- 2 BLOW INTO PVC TUBE ASSEMBLY TO PURGE WATER IN TUBE.
- 3 EXHAUST TRAPPED AIR IN TANK THROUGH PVC TUBE ASSEMBLY.
- 4 MAINTAIN SIDE TO SIDE STABILITY BY ALTERNATING FROM ONE TANK TO OTHER.
- 5 CONTINUE EXHAUSTING TRAPPED AIR UNTIL REAR OF LIFT HAS SUBMERGED.

**Construct a PVC Tube Assembly as shown**

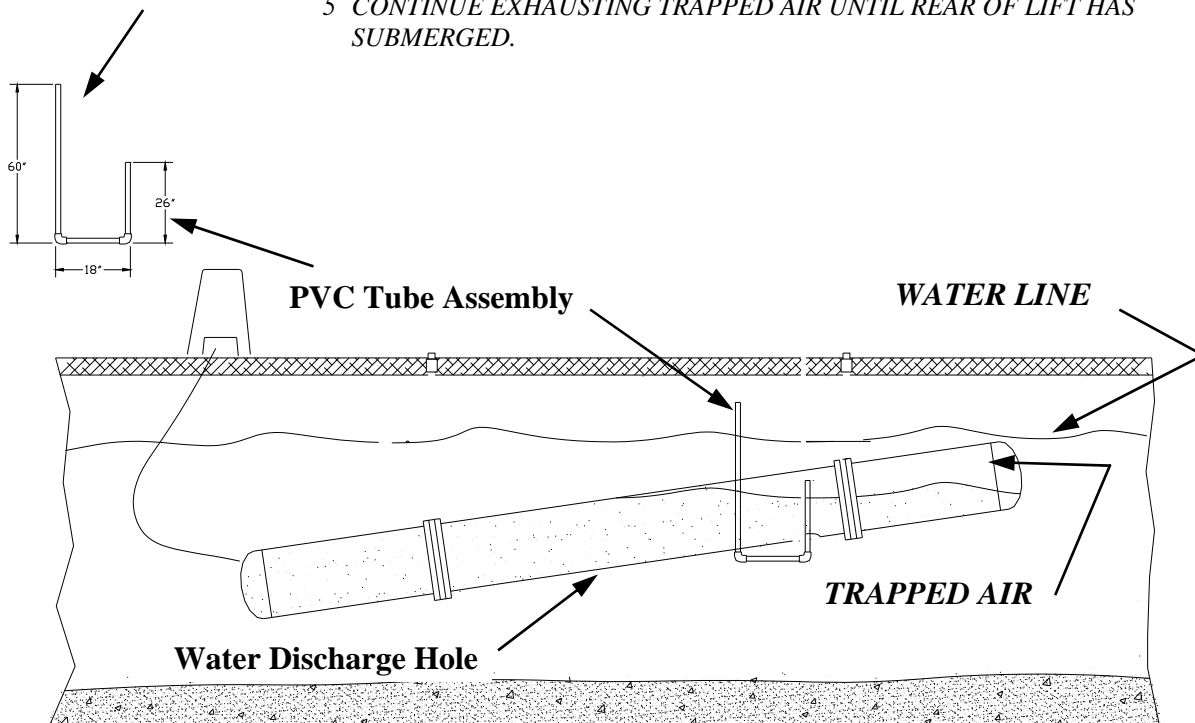

SHALLOW WATER			6000	6000 EP	6000 VS
Ref. No.	Pt. No.	Description			
1	5015530	TANK - UL2 6000 - YSN	2	2	2
2	4210080	TANK BRACKET- WELDMENT,UL2	4	4	4
3	4220502	TUBE BRACKET 6000-SHALLOW	4	4	4
4					
5	4211200	END CHANNEL X' X X" (see table A)	X	X	X
6	3056000	KEEL SPANNER 3" X 37-1/2"	SEE NOTE 1		
7	4520502	SIDE STIFFENER - 145 1/2			
8	4055600	ARM LH	2	2	2
9	4055500	ARM RH	2	2	2
10	2916730	SQUARE HOLE BUSHING	4	4	4
11	3050720	TORSION BAR (see table B)	X	X	X
12	3050000	TORQUE MANAGER	8	8	8
13	5057402	PITMAN (137 1/2")	2		2
14	4210001	UL2 SIDE BRACKET - PLASTIC	8	8	8
15	4031100	HULL SUPT COL - W/DOT	2	2	
16	5025600	HULL SUPPORT PAD 14 FT.	2	2	
17	3031700	HULL SUPPORT BRACE	2	2	
21	5048000	DOCK BRACKET HD COMPLETE	4	4	4
27	5203500	HYDROGUARD	4	4	4
28	4031110	HULL SUPT COL - W/OUT DOT	2	2	
29	5072650	HOSE ASSY - 1 1/4"	1	1	1
30	4220000	CNTRL UNIT 1V/1M - GEN 2	1	1	1
x	6960000	KIT BOX - 6000 UL2 SHALLOW	1	1	1
x	6917000	PARTS BAG - DOCK BRKT	1	1	1
x	6907000	KIT BAG VS PONTOON PADS			1
<b>VS - PONTOON PAD</b>					
19	5200300	VS 14' PONTOON PAD ASSY			2
20	3031500	PLATE FWD KEEL SUPPORT			4

<b>Table A</b>			<b>6000</b>		
			<b>Slip Width</b>		
<b>Ref. No.</b>	<b>Pt. No.</b>	<b>Description</b>	<b>10</b>	<b>12</b>	<b>14</b>
5	3050610	END CHANNEL 3" X 7'-11"	2		
5	3050640	END CHANNEL 3" X 9'-11"		2	
5	3050650	END CHANNEL 3" X 11'-11"			2

<b>Table B</b>			<b>6000</b>		
			<b>Slip Width</b>		
<b>Ref. No.</b>	<b>Pt. No.</b>	<b>Description</b>	<b>10</b>	<b>12</b>	<b>14</b>
11	3050730	TORSION BAR 7'-11"	2	2	
11	3050720	TORSION BAR 10'			2

<b>Note 1 (6000)</b>			<b>Slip Width</b>		
			<b>11</b>	<b>13</b>	
6	3056000	KEEL SPANNER 3" X 37-1/2"	4	4	
KEEL SPANNERS ARE USED ON INTERMEDIATE SLIP WIDTHS					

# INSTALLATION INTO AN EZ DOCK

**EZ Dock Installations** The HydroHoist Shallow Water model can easily be installed into EZ Docks Modular Dock System. Using 4 x Dock Bracket - EZ DOCK (Part # 4040600). The lift should be assembled as described in Sections 1 thru 3. (Fig R)

## Selecting Position for Boat & Hoist (BOW FIRST LOADING)

Step	Procedure
1.1	<b>BOW FIRST LOADING ONLY</b> Pull the <b>boat</b> into the boat stall so that the bow can be easily reached from the front of the slip, and allow at least 12 inches of space at the dock level between the dock and the boat in the event the boat may need to be later moved in final positioning.
1.2	With the boat in the desired location, place a mark on the dock where the boat's transom is positioned. <b>Note: Do not include extensions to the hull such as swim platforms; the transom mark should reflect the location of the the end of the bottom of the hull.</b>
1.3	Remove the boat and pull the <b>hoist</b> into the berth.
1.4	Position the hoist along side the dock and align the <b>rear end</b> of the Hull Support Pads with the <b>transom mark</b> on the dock.
1.5	With the hoist held stationary at this position, place <b>marks</b> on the dock at the location of the <b>Stabilizer Arm attachment points</b> .

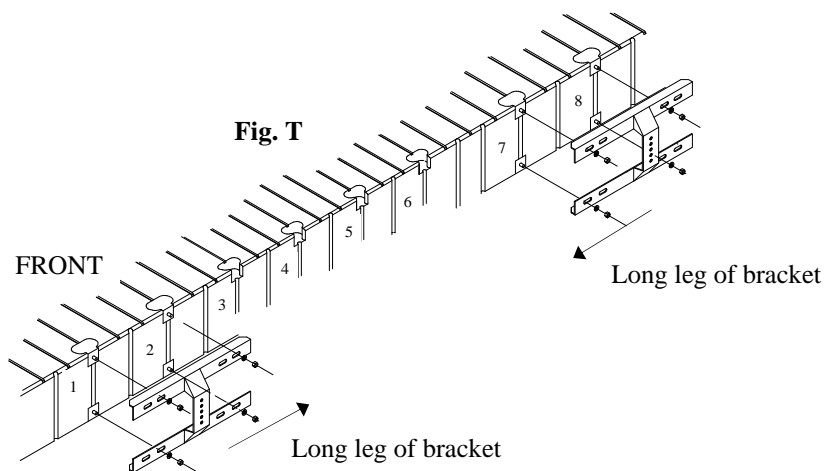
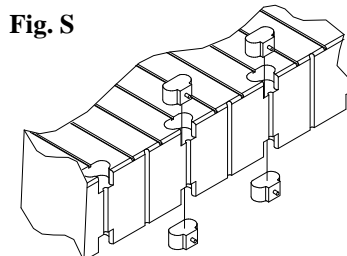
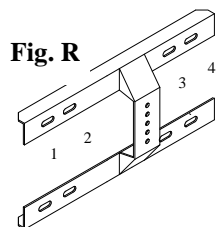

## Dock Bracket Attachment

Step	Procedure
2.1 <i>Fig S</i>	The EZ-Dock Dock Bracket is an asymmetrical part and can be attached to the dock in two different ways. Four EZ Dock couplers are required per dock bracket for attachment to the dock section.
2.2 <i>Fig R&amp;T</i>	Take one dock bracket to one of the front marks that show the stabilizer arm attachment points. Orient the dock bracket so that the longer horizontal legs of the bracket are facing the rear of the dock. Using holes 1 & 3 for the fixing to the coupler attach the bracket to the dock, using 4 x 15/16" lock washers and 4 x 15/16" nuts. Try to get the vertical face of the bracket as close to the mark on the dock as possible.
2.3 <i>Fig T</i>	EZ Dock Couplers should then be used in the 5th and 6th coupler seats from the bracket, leaving 4 empty coupler seats. An EZ-dock dock bracket should be attached to these couplers using holes 2 & 4, using 4 x 15/16" lock washers and 4 x 15/16" nuts. <b>REPEAT STEPS 2.1 THRU 2.3 ON OPPOSITE SIDE OF DOCK</b>

**Lift Attachment**  
*Fig. U*

Step	Procedure
3.1	Float hoist into position with the arms lined up with the Dock Brackets.
3.2	Loosen <i>front</i> "come-a-long" <u>only enough</u> to allow the <i>front</i> Stabilizer Arms [8-9] to slide between the vertical face of the Dock Bracket and the EZ-Dock.
3.3	SELECT PIVOT BOLT HEIGHT: The optimum Pivot Bolt location would be the center hole on the vertical face as shown in <i>Fig U</i> .
3.4	<b>FRONT ARMS ONLY</b> - Insert Poly & Stainless Steel Pivot Bushings into the Pivot End of <b>one front</b> Stabilizer Arm [8-9]. Attach Stabilizer Arm to vertical face of Dock Bracket - <i>it may be necessary to push down or lift up on the Arm to access the selected pivot location.</i> . Fasteners per Arm: (1 ea) Grade 8 - 5/8" x 3-1/2 bolt, flat washer, lock washer, & lock nut. <b>TIGHTEN AS TIGHT AS POSSIBLE (ABOUT 83 FT-LBS).</b>
3.5	<b>MEASURE THE DISTANCE FROM THE PIVOT BOLT TO THE WATER</b> - THIS DISTANCE WILL BE REPEATED FOR THE OTHER THREE ARMS - <b>ALL PIVOT BOLTS MUST BE AN EQUAL DISTANCE ABOVE THE WATER.</b>
3.6	Repeat Step 3.4 with opposite <i>front</i> Stabilizer Arm [8-9]. ( <b>Do Not</b> loosen or remove come-a-longs at this time). <b>TIGHTEN AS TIGHT AS POSSIBLE (ABOUT 83 FT-LBS).</b>
3.7	<b>REAR ARMS ONLY</b> - Insure hoist is square in the slip by measuring the distance between the right and left Stabilizer Arms [8-9] and the vertical faces of their Dock Brackets. If the distances <u>are not equal</u> , correct by moving one of the <b>front</b> Dock Brackets forward or backward in slots until the hoist is square in the slip.
3.8	Tighten <i>rear</i> "come-a-long" <u>only enough</u> to allow the <i>rear</i> Stabilizer Arms [8-9] to touch the vertical faces of the Dock Brackets. Attach Arms [8-9] to vertical faces as in Step 3.4. <b>TIGHTEN AS TIGHT AS POSSIBLE (ABOUT 83FT-LBS).</b> ( <b>Do Not</b> loosen or remove come-a-longs at this time). <b>NOTE-</b> <i>It may be necessary to stand on the rear of the hoist with the Control Unit Valve open (Launch) until hoist lowers enough to connect the rear Arms at the selected pivot locations....CAUTION - Maintain at least 4" of tank above the water, and be sure to <u>close the Valve</u> when position is achieved.</i>

**Fig.U**

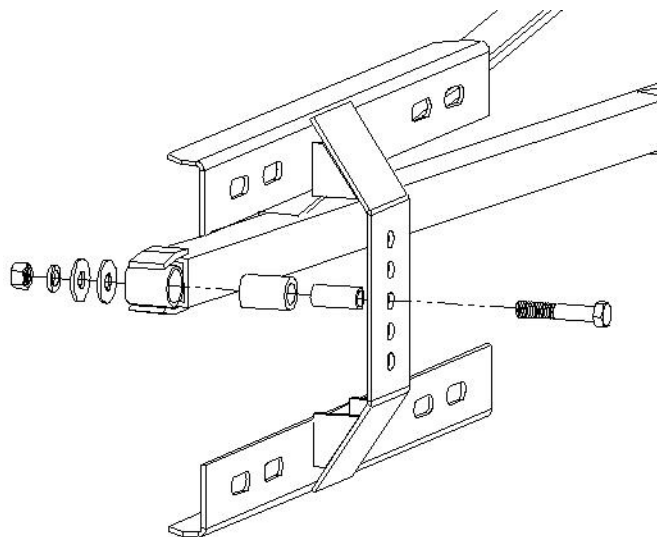

**Catch Chains**  
*Fig. V & W*

Step	Procedure
4.1	Remove the 3/8" x 2-1/4" bolt, double nuts and double flatwashers from the chains previously looped around the Side Stiffeners and Arms. Make a small but loose loop of chain around (each) Side Stiffener [7] only. Fasteners per Chain: (1 ea) 3/8" x 2-1/4" bolts, double nuts, and double flatwashers.
4.2	<p>Attach other end of Chain to vertical face at a point BELOW the Pivot Bolt. Fasteners per Chain: (1 ea) 3/8" x 2-1/4" bolts, double nuts, and double flatwashers. Tighten to 18 ft. lbs. torque.</p> <p><b>IMPORTANT:</b></p> <ol style="list-style-type: none"> <li>1. Chain length must be <b>equal length</b> on each side of hoist - unequal length may cause hoist to lift high and launch low on one side.</li> <li>2. Length of Chain (attachment point) is determined by:           <ul style="list-style-type: none"> <li>• The height of the attachment point above the water.</li> <li>• The draft of the boat.</li> </ul> </li> <li>3. The Ideal length allows the hoist to lower just enough to allow the boat to easily pass over hoist when boat is loaded with crew and gear, and in rising and falling waves.</li> <li>4. The Chains must never be loose when the hoist is in the fully down position - this indicates that the hoist is too low and the Stabilizer Arms are binding against the Pitmans possibly causing damage to parts.</li> </ol>

Fig.V

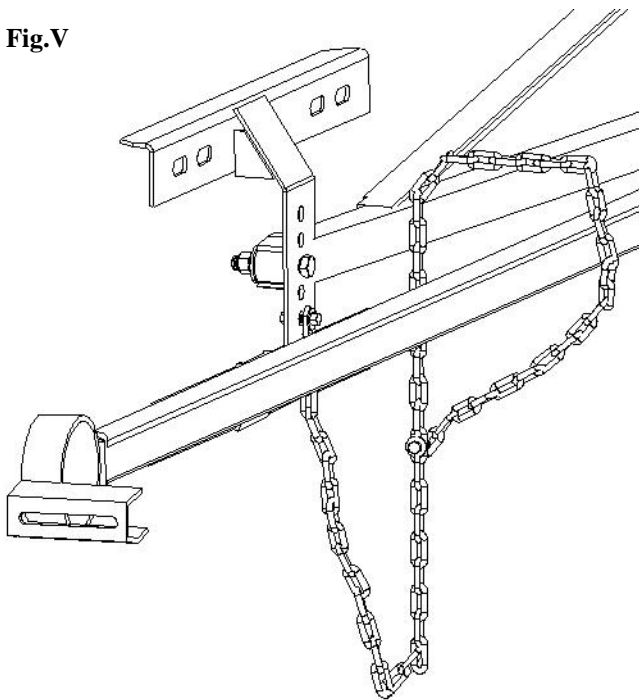
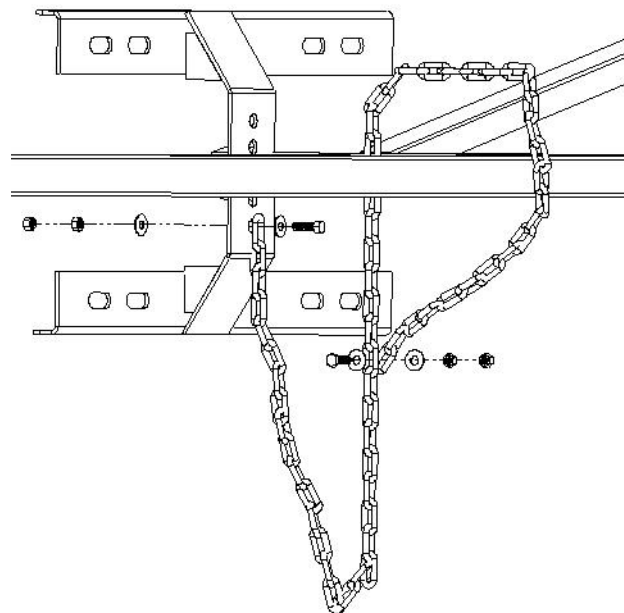
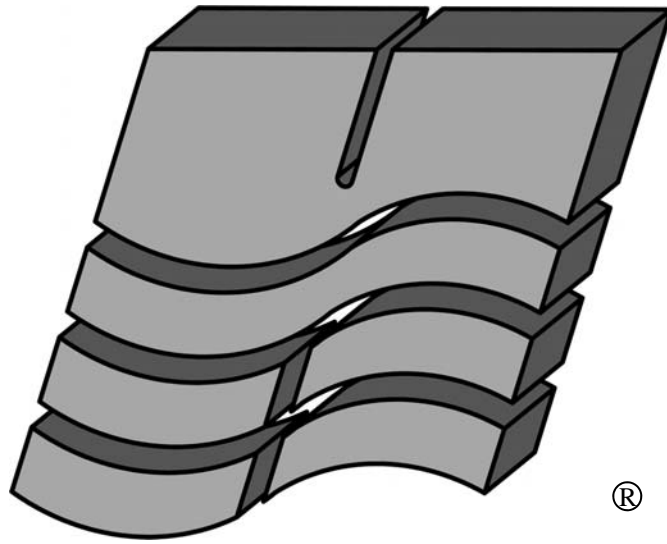

Fig.W





# ***SHALLOW WATER***

